

STATE OF HAWAII
DEPARTMENT OF TRANSPORTATION
AIRPORTS

SPECIFICATIONS AND PROPOSAL

FOR

INSPECTION AND MAINTENANCE
OF AIRPORT FIRE PROTECTION EQUIPMENT

DANIEL K. INOUE INTERNATIONAL AIRPORT, PROJECT NO. B01542-43
DILLINGHAM AIRFIELD, PROJECT NO. B02540-43
KALAELOA AIRPORT, PROJECT NO. B04540-43

ISLAND OF OAHU

NOTICE TO BIDDERS
Hawaii Revised Statutes (HRS),
Chapter 103D

The receiving of bids for INSPECTION AND MAINTENANCE OF AIRPORT FIRE PROTECTION EQUIPMENT, DANIEL K. INOUYE INTERNATIONAL AIRPORT, PROJECT NO. BO1542-43; DILLINGHAM AIRFIELD, PROJECT NO. BO2540-43; KALAELOA AIRPORT, PROJECT NO. BO4540-43; ISLAND OF OAHU, will begin as of the HiePRO Release Date. Bidders shall register and submit complete bids through HiePRO only.

Refer to the following HiePRO link for important information on Vendor Registration:

<https://hiepro.hawaii.gov/welcome.html>.

The solicitation specifications, proposal, and additional documents designated or incorporated by reference shall be available in HiePRO.

HiePRO OFFER DUE DATE & TIME is September 16, 2024, at 2:00 p.m., Hawaii Standard Time (HST). **Bidders shall submit and upload the complete proposal to HiePRO prior to the offer due date and time. Proposals received after said due date and time shall not be considered. Any additional support documents explicitly designated as confidential and/or proprietary shall be uploaded as a separate file to HiePRO. Bidders shall not include confidential and/or proprietary documents as part of their proposal. The record of each bidder and their respective proposal shall be open to public inspection. FAILURE TO UPLOAD THE PROPOSAL TO HiePRO SHALL BE GROUNDS FOR REJECTION.**

The scope of work consists of inspecting and maintaining fire extinguishers, fire sprinklers, and other fire protection equipment at Daniel K. Inouye International Airport, Dillingham Airfield and Kalaeloa Airport.

To be eligible for award, bidders shall possess a valid State of Hawaii Specialty Contractors "C-20" license **at the time of bidding**.

All Request for Information (RFI) questions and Substitution Requests shall be submitted in HiePRO **no later than September 9, 2024, at, 2:00 p.m., HST**. RFI questions received after the stated deadline shall not be addressed. Substitution Requests received after the stated deadline shall not be considered. Verbal RFI(s) shall not receive a response. All responses to RFI questions shall be provided for clarification and information only and issued by formal addendum. Any amendments to the solicitation shall be made by formal addendum and posted in HiePRO.

If there is a conflict between the solicitation and information stated in the responses to RFI questions, the solicitation shall govern and control, unless as amended by formal addendum.

Campaign contributions by State and County Contractors. Contractors are hereby notified of the applicability of HRS § 11-355 which states that campaign contributions are prohibited from specified State or county government contractors during the term of the contract if the contractors are paid with funds appropriated by a legislative body. For more information, contact the Campaign Spending Commission at (808) 586-0285.

Protests. Any protest of this solicitation shall be submitted in writing to the Director of Transportation, in accordance with HRS § 103D-701 and Hawaii Administrative Rules § 3-126.

The Equal Employment Opportunity Regulations of the Secretary of Labor implementing Executive Order 11246, as amended, shall be complied with on this project.

The U.S. Department of Transportation Regulation entitled “Nondiscrimination in Federally Assisted Programs of the U.S. Department of Transportation”, Title 49, Code of Federal Regulations (CFR), Part 21, is applicable to this project. Bidders are hereby notified that the Department of Transportation shall affirmatively ensure that the contract entered into

pursuant to this advertisement shall be awarded to the lowest responsible bidder without discrimination on the grounds of race, color, national origin, or sex (as directed by 23 CFR Part 200).

For additional information, contact Shaun Yamaki, Project Manager, by phone at (808) 838-8713, or by email at shaun.k.yamaki@hawaii.gov.

The State reserves the right to reject any or all proposals and to waive any defects in said proposals in the best interest of the public.



CURT T. OTAGURO
Deputy Director of Transportation for Airports

HIePRO RELEASE DATE: September 4, 2024

TABLE OF CONTENTS

	<u>PAGE</u>
Notice to Bidders	NTB-1 - NTB-3
Special Provisions.....	SP-1 - SP-7
Specifications	
Section 1 Definition of Terms	1-1 - 1-4
Section 2 Proposal Requirements and Conditions	2-1 - 2-3
Section 3 Award and Execution of Contract	3-1 - 3-5
Section 4 Scope of Work	4-1 - 4-3
Section 5 Control of Work	5-1 - 5-3
Section 6 Control of the Material and Equipment	6-1 - 6-3
Section 7 Legal Relations and Responsibility	7-1 - 7-4
Section 8 Prosecution and Progress	8-1 - 8-8
Section 9 Payment	9-1 - 9-2
Section 10 Fire Extinguisher, Fire Hose, Fire Extinguishing Systems, and Automatic Fire Sprinkler Systems Test, Inspection and Maintenance Services.....	10-1 - 10-20
Appendix A Equipment Location.....	A-1 - A-62
Proposal.....	PF-1 - PF-6
Proposal Schedule.....	PF-7 - PF-15
Forms	
Contract	
Certificate for Performance of Services	

STATE OF HAWAII
DEPARTMENT OF TRANSPORTATION
AIRPORTS

SPECIAL PROVISIONS

SPECIAL PROVISIONS

The Specifications contained herein are amended as follows:

A. SECTION 1 - DEFINITION AND TERMS is amended as follows:

1. The following definition shall be deleted in its entirety and replace with the following:

"1.33 SUBCONTRACTOR - An individual, partnership, firm, corporation, joint venture or other legal entity, as licensed or required to be licensed under Chapter 444, Hawaii Revised Statutes, as amended, which enters into an agreement with the Contractor to perform a portion of the work."

2. Add the following to the end of the section:

"1.39 HAWAII ePROCUREMENT SYSTEM (HIePRO) - The State of Hawaii eProcurement System for issuing solicitations, receiving proposals and responses, and issuing notices of award."

B. SECTION 2 - PROPOSAL REQUIREMENTS AND CONDITIONS is amended as follows:

1. 2.3 PROPOSAL GUARANTY is deleted in its entirety.

2. 2.4 DELIVERY OF PROPOSALS is amended by replacing the entire subsection with:

"2.4 DELIVERY OF PROPOSALS - Bidders shall submit and upload the complete proposal to HIePRO prior to the bid opening date and time. Proposals received after said due date and time shall not be considered. Any additional support documents explicitly designated as confidential and/or proprietary shall be uploaded as a separate file to HIePRO. Do not include confidential and/or proprietary documents with the proposal. The record of each bidder and respective bid shall be open to public inspection. Original (wet ink, hard copy) proposal documents are not required to be submitted. Contract award shall be based on evaluation of proposals submitted and uploaded to HIePRO.

FAILURE TO UPLOAD THE COMPLETE PROPOSAL TO HIePRO SHALL BE GROUNDS FOR REJECTION OF THE BID.

If there is a conflict between the specification document and the HIePRO solicitation, the specifications shall govern and control, unless otherwise specified.

3. 2.5 WITHDRAWAL OF PROPOSALS is amended by replacing The entire subsection with:

"2.5 WITHDRAWAL OF PROPOSALS - Bids may be modified or withdrawn prior to the bid opening date and time. Withdrawal or revision of proposal shall be completed, and submitted and uploaded to HIePRO prior to the bid opening date and time."

4. 2.6 PUBLIC OPENING OF PROPOSALS is not applicable.
5. Add the following to the end of the section:

"2.9 CERTIFICATION FOR PERFORMANCE OF SERVICES - Pursuant to Section 103-55, Hawaii Revised Statutes, and unless indicated otherwise, each bidder is required to submit the attached "Certificate for Performance of Services" in the event the bidder submits a bid in excess of \$25,000.00. This certificate must be submitted to said Contracts Office, Department of Transportation, 869 Punchbowl Street, Honolulu, Hawaii 96813, upon contract execution.

As of the bid opening date, salaries of State employees performing work similar to the work called for under this contract are as follows:

<u>Class</u>	<u>Salary Range</u>	<u>Minimum Hourly Rate</u>
Fire Extinguisher Services Worker	BC-04	\$26.04
Building Maintenance Worker	BC-09	\$32.64

The above information is provided to the Contractor for guidance only and is subject to change in accordance with existing collective bargaining contracts or shall change as contracts are renegotiated. It is the bidder's responsibility to verify the accuracy of the wage rates

contained herein and to provide for changes in the minimum wages, which must be paid personnel working on this project at all times. Information on the status of Bargaining Unit (BU) contracts can be obtained from the Airports Division, Personnel Management Office, (808) 838-8619.

Bidders are advised that they are not restricted to hire only those classifications of employees as listed, but are free to employ such other classifications of workers as the bidder deems proper and proposes to use on the project, and as may be according to the bidder's common hiring practice. However, the principal duties of employees other than those listed hereinabove working on the project will be matched against those of State workers to determine the closest equivalent State employee classification, and the Contractor must compensate such employee(s) at a rate which is no less than that of the equivalent State employee."

C. SECTION 6 - CONTROL OF MATERIAL AND EQUIPMENT

6.2 TRADE NAMES AND ALTERNATES is amended as follows:

A. The first paragraph of A. QUALIFICATION BEFORE BID OPENING shall be replaced with the following:

"A. QUALIFICATION BEFORE BID OPENING - When the specifications and/or plans specify one or more manufacturer's brand names of materials or equipment to indicate a quality, style, appearance, or performance, the bidder will be assumed to have based its bid on one of the specified named products, except where such proprietary product are specified, alternate brands may be qualified if found equal or better by the Department. The bidder shall submit a request to the Department for review and approval at the earliest date possible. Requests shall be submitted via email to the Contact person listed in HIePRO for the solicitation and also posted as a question in HIePRO under the question/answer tab referencing the email with the request. The request must be posted in HIePRO no later than fourteen (14) calendar days before the bid opening date."

B. The first sentence of the second paragraph of A. QUALIFICATION BEFORE BID OPENING shall be replaced with the following:

"It shall be the responsibility of the bidder to submit sufficient evidence based upon which a determination can be made by the Department that the alternate brand name is a qualified equivalent."

D. SECTION 7 - LEGAL RELATIONS AND RESPONSIBILITY is amended as follows:

7.8 LABOR AND COMPENSATION REQUIREMENTS - is amended by replacing the first two paragraphs with the following:

Pursuant to Section 103-55, H.R.S., Wages, Hours, Working Conditions of Employees of Contractor's Supplying Services, services to be rendered shall be performed by employees paid at wages or salaries not less than the wages paid to public officers and employees for similar work.

Additional information on the requirements of Section 103-55, H.R.S. may be obtained at http://www.capitol.hawaii.gov/hrscurrent/Vol02_Ch0046-0115/HRS0103/HRS_0103-0055.htm"

7.9 INSURANCE is amended as follows:

1. 7.9 (B) COMPREHENSIVE AUTOMOBILE LIABILITY is amended by replacing the first sentence with the following:

"The Contractor shall obtain Auto Liability Insurance covering all owned, non-owned, and hired autos with a combined single limit of not less than \$5,000,000 per accident for bodily injury and property damage with the State of Hawaii named as additional insured."

2. 7.9 (C) COMMERCIAL GENERAL LIABILITY is amended by replacing the first sentence with the following:

"The Contractor shall obtain General Liability Insurance with a limit of not less than \$5,000,000 per occurrence and in the aggregates.

Subcontractors, vendors, or other parties working under the Contractor shall abide by the same requirements."

Add the following subsection:

"7.10 SPECIAL REQUIREMENTS FOR CONTRACTOR'S OPERATIONS IN THE AIRPORT OPERATIONAL AREAS (AOA) - The Contractor shall

conform with the applicable sections of the State Airports Program Rules and Regulations pertaining to its access and operation in the AOA hereinafter described as follows:

A. Comprehensive General Liability Insurance - The Contractor shall obtain and maintain during the course of work, insurance coverage as specified by Section 7.9.

B. Authorized Vehicles

1. Only vehicles considered safe and necessary for the performance of this contract shall be allowed to operate in the AOA.
2. All authorized vehicles shall be identified with the Contractor's company name on each side with letters not less than four (4) inches in height or a logo no less than six (6) inches in height.
3. As a condition to enter and operate in the AOA, the Contractor shall obtain insurance coverage as required by Section 7.9.
4. The Contractor's operations on, over, across, and/or immediately adjacent to any runway and/or taxiway at a towered airport may require the use of a two-way radio communication. The Contractor shall obtain the necessary equipment at its own expense.
5. No person shall operate a motor vehicle on the AOA without personally possessing a current Motor Vehicle Operator's Permit issued by the Airport Manager to that person.
 - a. The Motor Vehicle Operator's Permit will be issued only to persons who apply through the Airport Security Section and pass a written exam covering those portions of the Airport Rules and Regulations relating to the operation of vehicles in the AOA.
 - b. Permits issued may be suspended or revoked for cause at any time by the Airports Division.

C. Airport Operational Area Identification Badge - Contractor's employees requiring entrance to the AOA must apply and obtain identification badges through the Airport Security Office.

1. All persons employed under this contract who have unescorted access to the AOA shall have background checks (to the extent permitted by law) including at a minimum, references and prior employment histories by the employees relating to employment in the preceding ten (10) years.
2. As a condition in the issuance of AOA Identification Badges, Certification of Compliance shall be submitted with the application. The Certification shall affirm that a background check has been performed, correct and complete of those persons requiring access to the AOA. Background check records shall be maintained by the Contractor during the course of the work and shall contain the name, address, social security number, and previous employment and the person(s) contacted to verify such employment. The records shall be made available for inspection by the State.

E. SECTION 8 - PROSECUTION AND PROGRESS is amended as follows:

Subsection 8.2 SUBCONTRACTING is amended by adding the following sentence after the first (1st) sentence in the second (2nd) paragraph:

"The Contractor, however, shall perform with its own organization, work amounting to not less than fifty percent (50%) of the total contract cost."

F. SECTION 9 - PAYMENT is amended by adding the following subsection:

"9.6 RELEASE OF RETAINAGE - The State may release the payments withheld (retainage) at the end of one-year term provided:

- (a) The Contractor has satisfactorily fulfilled the terms and conditions of the Contract for that one-year term.

(b) The Contractor submits a current tax clearance certificate."

STATE OF HAWAII
DEPARTMENT OF TRANSPORTATION
AIRPORTS

SPECIFICATIONS

SECTION 1 - DEFINITION AND TERMS

Whenever the following pronouns are used in these specifications, or in any documents or instruments where these specifications govern, the intent and meaning shall be interpreted as follows:

1.1 ADDENDA - A written document which may be issued by the Director during the bidding period involving changes to the specifications and plans, if any, which shall be considered and made a part of the contract.

1.2 AIRPORTS DIVISION - Airports Division, Department of Transportation, State of Hawaii.

1.3 AWARD - The written acceptance of a proposal by the State.

1.4 BIDDER - Any individual, partnership, corporation or other legal entity, or combination thereof, submitting a proposal for the work contemplated, acting either directly or through a duly authorized representative.

1.5 CALENDAR DAY - Every day shown on the calendar. If no designation of calendar or working day is made, "day" shall mean calendar day.

1.6 CHANGE ORDER - A written order issued by the Director to the Contractor requiring the contract work to be performed in accordance with a change or changes that may involve an adjustment in contract time and price or requiring performance of any unforeseen work essential to complete the contract.

1.7 CONTRACT - The written agreement between the State and the Contractor setting forth the obligations of the parties thereunder, including, but not limited to, the performance of the work, the furnishing of labor and materials, and the basis of payment.

The contract includes the (1) notice to bidders, (2) proposal, (3) contract form and contract bond, (4) specifications, (5) special provisions and plans, if any, (6) addenda, (7) notice to proceed, and (8) change orders and agreements that are required to complete the work, all of which constitute one instrument.

1.8 CONTRACT BOND - The approved form of security, executed by the Contractor and its Surety or Sureties, guaranteeing the completion of the work in accordance with the terms of the contract, and guaranteeing full payment of all claims for labor, materials, and supplies used or incorporated in the work.

1.9 CONTRACT TIME - The number of working days or calendar days allowed for completion of the contract, including authorized time extensions.

If a calendar date is specified as the date of completion in lieu of the number of working days or calendar days, the contract shall be completed by that date.

In case the contract is for a specified period of time, the contract time shall be for said specified period of time.

1.10 CONTRACTOR - The individual, partnership, corporation or other legal entity, or combination thereof, contracting with the State for performance of the prescribed work.

1.11 DEPARTMENT - The State Department of Transportation.

1.12 DIRECTOR - The Director of Transportation, acting either directly or through the Director's duly authorized representative.

1.13 EQUAL OR APPROVED EQUAL - Whenever this term is used in the specifications and plans, if any, it means a brand or article pre-qualified in accordance with Section 6.2 Trade Names and Alternates and which may be used in place of the one specified.

1.14 H.A.R. or HAR - Hawaii Administrative Rules.

1.15 H.R.S. or HRS - Hawaii Revised Statutes.

1.16 HARBORS DIVISION - Harbors Division, Department of Transportation, State of Hawaii.

1.17 HIGHWAYS DIVISION - Highways Division, Department of Transportation, State of Hawaii.

1.18 HOLIDAYS - The days which are set apart and established as State holidays pursuant to Section 8-1, H.R.S.

1.19 INSPECTOR - The Director's authorized representative assigned to make detailed inspections of contract performance and materials supplied.

1.20 NOTICE TO BIDDERS - The public announcement, as required by law, inviting proposals for the work to be performed or materials to be furnished.

1.21 NOTICE OF FINAL ACCEPTANCE - Written notice from the Director to the Contractor that the entire contract has been completed in all respects in accordance with the specifications and plans, if any, and any changes thereof previously approved by the Director.

1.22 NOTICE TO PROCEED - Written notice from the Director to the Contractor advising the Contractor of the date on which he is to begin the prosecution of the work.

1.23 PLANS - The contract drawings approved by the Director which show the location, character, dimensions and details of the work to be done and shall be a part of the contract.

1.24 PROCUREMENT OFFICER - The Director's duly authorized representative including project managers, project engineers and contract administrators assigned to prepare, evaluate and administer contracts for the purchasing of goods and services.

1.25 PROPOSAL (OR BID) - The offer of a bidder, on the prescribed form, to perform the work and to furnish the labor and materials at the prices quoted.

1.26 PROPOSAL FORM - The approved format prepared by the Department or a facsimile thereof on which bids for the work must be prepared and submitted. (Reasonable facsimile acceptable for bidding.)

1.27 PROPOSAL GUARANTY - The security furnished with a proposal to guarantee that the bidder will enter into the contract and furnish all other requirements if the bidder's proposal is accepted.

1.28 QUALIFICATION QUESTIONNAIRE - The specified forms on which the bidder shall furnish required information as to the bidder's ability to perform and finance the work.

1.29 S.L.H. or SLH - Session Laws of Hawaii.

1.30 SPECIAL PROVISIONS - Revisions to the specifications. The specific clauses setting forth conditions or requirements peculiar to the project under consideration which are not thoroughly or satisfactorily stipulated in these specifications.

1.31 SPECIFICATIONS - The directions, provisions, and requirements pertaining to the method and manner of performing the work and to the quantities and qualities of materials to be furnished under the contract.

1.32 STATE - The State of Hawaii.

1.33 SUBCONTRACTOR - An individual, partnership, corporation, other legal entity, or any combination thereof, that enters into an agreement with the Contractor to perform a portion of the work for the Contractor.

1.34 SUPERINTENDENT - The Contractor's representative who is responsible for and in charge of the work.

1.35 SURETY - The corporation, partnership or individual, other than the Contractor, executing a bond furnished by the Contractor and guaranteeing performance by the Contractor.

1.36 TITLES (OR HEADINGS) - The titles or headings of the Sections herein are intended for convenience of reference and shall not be considered as having any bearing on their interpretation. Unless otherwise indicated, whenever the word "Section" is used, reference is being made to a Section in these specifications.

1.37 WORK - The furnishing of all labor, materials, equipment, and other incidentals necessary or convenient for the successful completion of the project and the execution of all the duties and obligations imposed by the contract.

1.38 WORKING DAY - Any day, except Saturdays, Sundays and State holidays.

SECTION 2 - PROPOSAL REQUIREMENTS AND CONDITIONS

2.1 QUALIFICATION OF BIDDERS - Prospective bidders must be capable of performing the work for which bids are called.

In accordance with Section 103D-310, HRS, the Department may require any prospective bidder to submit answers to questions contained in the "Standard Qualification Questionnaire for Prospective Bidders on Public Works Contracts" on the form furnished by the Department, properly executed and notarized, setting forth a complete statement of the experience of such prospective bidder and its organization in performing similar work and a statement of the equipment proposed to be used, together with adequate proof of the availability of such equipment. Whenever it appears to the Department, from answers to the questionnaire or otherwise, that the prospective bidder is not fully qualified and able to perform the intended work, the Department will, after affording the prospective bidder an opportunity to be heard and if still of the opinion that the bidder is not fully qualified to perform the work, refuse to receive or consider any bid offered by the prospective bidder. All information contained in the answers to the questionnaire shall be kept confidential. Questionnaire so submitted shall be returned to the bidders after serving their purpose.

Failure to complete the qualification questionnaire will be sufficient cause for the Department to disqualify a prospective bidder.

No person, firm or corporation may bid where (1) the person, firm, or corporation, or (2) a corporation owned substantially by the person, firm, or corporation, or (3) a substantial stockholder or an officer of the corporation, or (4) a partner or substantial investor in the firm is in arrears in payments owed to the State of Hawaii or its political subdivisions or is in default as a surety or failure to do faithfully and diligently previous contracts with the State.

2.2 REJECTION OF PROPOSALS CONTAINING ALTERATIONS, ERASURES, OR IRREGULARITIES - Proposals may be rejected if they show any alterations of form, additions not called for, conditional bids, incomplete bids, erasures, or irregularities of any kind.

When proposals are signed by any agent, other than the officer or officers of a corporation authorized to sign contract on its behalf or a member of copartnership, a Power of Attorney must be on file with the Department prior to opening bids or shall be submitted with the proposal; otherwise, the proposal may be rejected as irregular and unauthorized.

Members of a joint venture may be requested to supply the Department with a copy of their joint venture agreement or each member of the joint venture may be required to sign the proposal.

2.3 PROPOSAL GUARANTY - A proposal guaranty (bid bond) is not required except when specifically noted in the proposal section of the bid document.

When a proposal guaranty is required with a bid, it will be specifically stated in the proposal; and no proposal totaling \$25,000 or more will be considered unless accompanied by one of the following forms of bidder's security:

- A. a deposit of legal tender; or
- B. a surety bid bond underwritten by a company licensed to issue bonds in the State of Hawaii and submitted on the standard form provided herewith; or
- C. a certificate of deposit, share certificate, cashier's check, treasurer's check, teller's check, or official check drawn by, or a certified check accepted by and payable on demand to the State by a bank, savings institution, or credit union insured by the Federal Deposit Insurance Corporation (FDIC) or the National Credit Union Administration (NCUA).
 - 1. The bidder may use these instruments only to a maximum of one hundred thousand dollars (\$100,000.00).
 - 2. If the required security or bond amount totals over one hundred thousand dollars (\$100,000.00), more than one instrument not exceeding one hundred thousand dollars (\$100,000.00) each and issued by different financial institutions shall be acceptable.
 - 3. The instrument shall be made payable at sight to the Department of Transportation, State of Hawaii.

According to Section 103D-323, HRS, the above shall be in a sum not less than five percent (5%) of the amount bid.

2.4 DELIVERY OF PROPOSALS - Each proposal shall be placed, together with the proposal guaranty when required, in an envelope and sealed and so marked as to indicate the identity of the project, the name and address of the bidder, and other required information and then delivered as indicated in the Notice to Bidders. Proposals will be received up to the time fixed in the Notice to Bidders for the opening of bids.

2.5 WITHDRAWAL OF PROPOSALS - Any proposal may be withdrawn at any time prior to the time fixed in the Notice to Bidders for the opening of proposals upon the filing of a written request therefore with the Department, executed by the bidder or a duly authorized representative. The withdrawal of a proposal shall not preclude a bidder from submitting a new proposal.

2.6 PUBLIC OPENING OF PROPOSALS - Proposals will be opened and read publicly at the time and place indicated in the Notice to Bidders. Bidders or their authorized agents are invited to be present.

2.7 DISQUALIFICATION OF BIDDERS - Any of the following reasons may be considered as being sufficient grounds for the disqualification of a bidder and the rejection of his proposal or proposals.

- A. More than one proposal for the same work from an individual, firm, or corporation under the same or different name.
- B. Evidence of collusion among bidders. Participants in such collusion will receive no recognition as bidders for any future work of the Department until such participant shall have been reinstated as a qualified bidder.
- C. Evidence of assistance from a person who has been an employee of the agency within the preceding two years and who participated while in State office or employment in the matter with which the contract is directly concerned, pursuant to Section 84-15, H.R.S.
- D. Lack of proposal guaranty.
- E. Unsigned proposal or proposal not signed in ink by person or persons legally authorized to submit a proposal on behalf of the bidder.

2.8 MATERIAL GUARANTY - The bidder may be required to furnish a complete statement of the origin, composition and manufacture of any or all materials to be used in the prosecution of the work, together with samples. Such samples may be subjected to tests to determine their quality and fitness for the work.

SECTION 3 - AWARD AND EXECUTION OF CONTRACT

3.1 AWARD OF CONTRACT - The State reserves the right to reject any and all proposals and to waive any defects as may be deemed to be in the best interest of the public.

The award of contract, if it be awarded, shall be made within sixty (60) calendar days after the opening of bids to the lowest responsive and responsible bidder whose proposal complies with all the prescribed requirements. The Department may request the bidders to allow the Department to consider the bids for the issuance of an award beyond the sixty (60) calendar day period. Agreement to such an extension shall be made by a bidder in writing. Only bidders who have agreed to such an extension shall be eligible for the award.

Requirement for award. The Bidder, as proof of compliance with the requirements of section 103D-310(c), HRS, upon award of a contract made pursuant to section 103D-302, HRS, shall provide the documents listed below. The documents shall be submitted promptly to the Department. If a valid certificate/clearance is not submitted on a timely basis upon award, the Bidder may be deemed non-responsible.

A. Tax Clearance.

Pursuant to section 103D-310(c), 103-53 and 103D-328, HRS, the bidder shall submit a tax clearance certificate from the State of Hawaii Department of Taxation (DOTAX) and the Internal Revenue Service (IRS), subject to section 103D-328, HRS, current within six months of issuance date.

FORM A6, TAX CLEARANCE CERTIFICATE, is available at the following website:

<https://tax.hawaii.gov/>

To receive DOTAX Forms by fax or mail, phone (808)587-4242 or 1-800-222-3229.

The application for the Tax Clearance Certificate is the responsibility of the bidder. Bidder shall submit directly to the DOTAX or IRS. The approved certificate may then be submitted to the Department.

B. Certificate of Compliance.

Pursuant to section 103D-310(c), HRS, the bidder shall submit a certificate of compliance for Hawaii Employment Security Law (Chapter 383, HRS), Workers' Compensation Law (Chapter 386, HRS), Temporary Disability Insurance (Chapter 392, HRS), and Prepaid Health Care Act (Chapter 393, HRS), from the State of Hawaii Department of Labor and Industrial Relations (DLIR), current within six months of issuance date.

Form LIR#27, Application for Certificate of Compliance with section 3-122-112, HAR, is available at the following website:

<https://labor.hawaii.gov/>

Contact the DLIR Unemployment Insurance Division at (808) 586-8926 for additional information.

Inquiries regarding the status of a LIR#27 Form are available from the DLIR Disability Compensation Division at (808)586-9200.

The application for the Certificate of Compliance is the responsibility of the bidder. Bidder shall submit directly to the DLIR. The approved certificate may then be submitted to the Department.

C. Certificate of Good Standing.

Pursuant to section 103D-310(c), HRS, the bidder shall submit a certificate of good standing from the business registration division (BREG) of the State of Hawaii Department of Commerce and Consumer Affairs (DCCA), current within six months of issuance date, to demonstrate it is either:

- (1) incorporated or organized under the laws of the State; or
- (2) registered to do business in the State as a separate branch or division that is capable of fully performing under the contract.

A Hawaii business that is a sole proprietorship, is not required to register with the BREG, and therefore not required to submit a certificate of good standing. Bidders are advised of costs associated

with registering and obtaining a Certificate of Good Standing from the DCCA.

To purchase a Certificate of Good Standing, go to On-Line Services at the following website:

<https://cca.hawaii.gov/>

The application for the Certificate of Good Standing is the responsibility of the bidder. Bidder shall submit directly to the DCCA. The approved certificate may then be submitted to the Department.

- D.** IN LIEU OF the certificates referenced in subsection A, B, and C, bidder may make available proof of compliance through a state procurement office designated certification process.

3.2 CANCELLATION OF AWARD - The State reserves the right to cancel the award of any contract any time before the execution of said contract by all parties without any liability to the successful bidder or any other bidder.

3.3 RETURN OF PROPOSAL GUARANTY - All proposal guaranties, except those of the lowest two (2) bidders, will be returned immediately following the opening and checking of the proposals. The retained proposal guaranty of the second lowest bidder, if not a bid bond, will be returned within ten (10) calendar days following execution of contract by the successful bidder. The successful bidder's proposal guaranty, if not a bid bond, will be returned after a satisfactory contract bond has been furnished and the contract has been executed.

3.4 REQUIREMENT OF CONTRACT BOND - Only when required by the proposal, the successful bidder at the time of the execution of the contract shall file good and sufficient performance and payment bonds on the forms furnished by the Department, or a facsimile thereof, conditioned for the full and faithful performance of the contract in accordance with the terms and intent thereof and also for the prompt payment to all others for all labor and materials furnished by them to it and use in the prosecution of the work provided for in such contract, in the manner, form and amount required by Section 3-122-224(b) (2), H.A.R., which bonds shall be in an amount equal to fifty per cent (50%) of the contract price, including amounts estimated to be required for extra work, or in the case of price-term, open-end, or requirements contract under which the total amount to be paid to the Contractor cannot be accurately estimated at the time the contract is to be awarded, the bond amounts shall be as designated in the bid documents. Such bonds shall also by

their terms inure to the benefit of any and all persons entitled to file claims for labor performed or materials furnished in the work so as to give them a right of action as contemplated by Section 103D-324, H.R.S.

The bidder shall limit the acceptable performance and payment bonds to the following:

- (a) Legal tender; or
- (b) Surety bond underwritten by a company licensed to issue bonds in the State of Hawaii; or
- (c) A certificate of deposit; share certificate,; cashier's check; treasurer's check; teller's check drawn by or a certified check accepted by and payable on demand to the State by a bank, savings institution or credit union insured by the Federal Deposit Insurance Corporation (FDIC) or the National Credit Union Administration (NCUA).

1. The bidder may use these instruments only to a maximum of one hundred thousand dollars (\$100,000.00).

2. If the required security or bond amount totals over one hundred thousand dollars (\$100,000.00) more than one instrument not exceeding one hundred thousand dollars (\$100,000.00) each and issued by different financial institutions shall be acceptable.

3.5 EXECUTION OF CONTRACT - The contract and the "Certificate for Performance of Services", similar to a copy of the same annexed hereto, shall be executed by the successful bidder and returned, together with the contract bonds, when required, within ten (10) days after the award of the contract or within such further time as the Director may allow after the bidder has received the contract for execution.

Pursuant to Section 103D-309, H.R.S., the contract shall not bind the State in any way unless said contract has been fully and properly executed by all the parties thereto and the Comptroller has endorsed thereon a certificate that there is available an unexpended appropriation over and above all outstanding contracts, sufficient to cover the amount required by the contract.

3.6 FAILURE TO EXECUTE CONTRACT - Failure to execute the contract, Certificate for Performance of Services and file acceptable bonds, when required, within ten (10) days after

the award of the contract, or within such further time as the Director may allow, shall be cause for the cancellation of the award and the forfeiture of the proposal guaranty. Award of the contract may then be made to the next lowest responsible bidder.

SECTION 4 - SCOPE OF WORK

4.1 WORK TO BE DONE - The work to be done is described in the Section(s) following Section 9 of these specifications.

4.2 PERFORMANCE OF WORK - The Contractor shall employ, so far as possible, such methods and means in carrying out his work so as not to cause any interruption, disturbance, or interference with the public.

In case the Contractor is performing work in a building, the Contractor shall conduct the work in such a manner so as not to cause any interruption, disturbance, or interference with the business activities of the tenants in the building.

4.3 EXTRA WORK - New and unforeseen items of work will be classed as extra work when they cannot be covered by any of the various items for which there is a bid price.

4.4 CHANGES AND CLAIMS FOR ADJUSTMENT

A. Change order. By a written order, at any time, and without notice to any surety, the procurement officer may, subject to all appropriate adjustments, make changes within the general scope of this contract in any one or more of the following:

1. Drawings, designs, or specifications, if the goods to be furnished are to be specially manufactured for the State in accordance therewith;
2. Method of shipment or packing;
3. Place of delivery;
4. Changes in the work within the scope of the contract; or
5. Changes in the time of performance of the contract that do not alter the scope of work.

B. Adjustments of price or time for performance. If any change order increases or decreases the contractor's cost of, or the time required for, performance of any part of the work under this contract, whether or not changed by the order, an adjustment shall be made and the contract modified in writing accordingly. Any adjustment in contract price made pursuant to this clause shall be determined in accordance with the price adjustment clause of this contract. Failure of the parties to agree to an adjustment shall not excuse the contractor from proceeding with the contract as changed, provided that the procurement officer promptly and duly make the provisional adjustments in payment or time for performance as may be reasonable. By proceeding with the work, the contractor shall not be deemed to have

prejudiced any claim for additional compensation, or an extension of time for completion.

C. Time period for claim. Within thirty (30) days after receipt of a written change order under subsection (a) unless the period is extended by the procurement officer in writing, the contractor shall file notice of intent to assert a claim for an adjustment. Later notification shall not bar the contractor's claim unless the State or county is prejudiced by the delay in notification.

D. Claim barred after final payment. No claim by the contractor for an adjustment hereunder shall be allowed if notice is not given prior to final payment under this contract.

E. Other claims not barred. In the absence of a change order, nothing in this clause shall be deemed to restrict the contractor's right to pursue a claim as under the contract or for breach of contract.

4.5 PRICE ADJUSTMENT

Any adjustment in contract price pursuant to a clause in this contract shall be made in one or more of the following ways:

A. By agreement on a fixed price adjustment before commencement of the pertinent performance or as soon thereafter as practicable;

B. By unit prices specified in the contract or subsequently agreed upon;

C. By the costs attributable to the event or situation covered by the clause, plus appropriate profit or fee, all as specified in the contract or subsequently agreed upon;

D. In such other manner as the parties may mutually agree; or

E. In the absence of agreement between the parties, by a unilateral determination by the procurement officer of the costs attributable to the event or situation covered by the clause, plus appropriate profit or fee, all as computed by the procurement officer in accordance with generally accepted accounting principles and applicable sections of chapters 3-123 and 3-126 of the Hawaii Administrative Rules.

4.6 VARIATION IN QUANTITY

Upon agreement of the parties, the quantity of goods or services or both specified in this contract may be increased by a maximum of ten (10) percent provided (1) the unit prices will remain the same except for any price adjustments otherwise applicable and (2) the procurement officer makes a written determination that such an increase will either be more economical than awarding another contract or that it would not be practical to award another contract.

SECTION 5 - CONTROL OF WORK

5.1 AUTHORITY OF DIRECTOR - The Director shall decide all questions which may arise as to the quality or acceptability of materials furnished and work performed; the manner of performance and rate of progress of the work; the compensation for work performed; the interpretation of the contract and the fulfillment of the contract on the part of the Contractor. The Director's decision shall be final and the Director shall have the authority to enforce any such decision and order which the Contractor fails to carry out promptly and diligently. The Director shall have the following powers in the way of enforcement:

- A. The right to suspend the work.
- B. The right to withhold payment due the Contractor.

5.2 COORDINATION OF PLANS, SPECIFICATIONS AND SPECIAL PROVISIONS - These specifications, the plans, special provisions, and all supplementary documents are essential parts of the contract, and a requirement occurring in one is as binding as though occurring in all. They are intended to describe and provide for the complete work.

5.3 COOPERATION OF CONTRACTOR AND DIRECTOR - The Contractor shall have available at the work site at all times, a copy of the specifications, special provisions and plans. The Contractor shall give the work constant attention to facilitate the progress thereof and shall cooperate with the Director in every way possible.

Before starting work on the project, the Contractor shall designate in writing a superintendent who shall have complete authority to represent and to act for the Contractor.

5.4 INSPECTION - The Director at all times shall have access to the work during its prosecution and shall be furnished with every reasonable facility for ascertaining that the materials and the workmanship are in accordance with the requirements and intentions of these specifications and special provisions. All work done and all materials furnished shall be subject to the Director's inspection and approval.

The inspection of the work shall not relieve the Contractor of any of its obligations to fulfill its contract as prescribed, and defective work shall be made good and unsuitable materials may be rejected, notwithstanding that such defective work and materials may have been previously overlooked by the Director and accepted or included in an estimate for payment.

Projects financed in whole or in part with Federal funds shall be subject to inspection at all times by representatives of the Federal agency involved.

5.5 REMOVAL OF DEFECTIVE AND UNAUTHORIZED WORK - All work which has been rejected shall be corrected or removed and replaced by the Contractor in an acceptable manner and no compensation will be allowed the Contractor for such correction or removal and replacement. Upon failure on the part of the Contractor to comply promptly with any order of the Director, the Director may cause any rejected work to be corrected or removed and replaced and to deduct the costs thereof from any monies due or to become due the Contractor.

5.6 CLAIMS AND DISPUTES - The Contractor may give notice in writing to the Director for claims that extra compensation, damages, or an extension of time for completion is due the Contractor for one or more of the following reasons:

- A. Requirements not clearly covered in the contract, or not ordered by the Director as extra work;
- B. Failure between the State and the Contractor to agree to an adjustment in price for a contract change order issued by the State; or
- C. An action or omission on the part of the Director requiring performance changes within the scope of the contract.

The Contractor shall continue with performance of the contract in compliance with the directions or orders of the procurement officer, but by so doing, the Contractor shall not be deemed to have prejudiced any claim for additional compensation, damages, or an extension of time for completion; provided:

- A. The notice in writing be given:
 - 1. Before the commencement of the work involved, if at that time the Contractor knows of such requirements or the occurrence of such actions or omissions; or
 - 2. Within thirty (30) calendar days after the Contractor knows of such requirements or the occurrence of such action or omission if the Contractor did not have such knowledge before the commencement of the work; or
 - 3. Within thirty (30) calendar days after receipt of the written contract change order that was not

agreed upon by both parties; or

4. Within such further time as may be allowed by the Director in writing.

B. The notice shall clearly state the Contractor's intention to make claim and the reasons why the Contractor believes that additional compensation, changes or an extension of time may be remedies to which the Contractor is entitled; and afford the Director every facility for keeping records of the actual cost of work. Failure on the part of the Contractor to give such notification or to afford the procurement officer proper facilities for keeping strict account of actual cost shall constitute waiver of the claim for such extra compensation. The filing of such notice by the Contractor and the keeping of costs by the procurement officer shall not in any way be construed to prove the validity of the claim.

The Director will review the notice and render a decision. The Director's decision shall be final and conclusive unless, within thirty (30) calendar days from the date of the decision, the Contractor mails or otherwise furnishes a written appeal to the Director. The decision of the Director shall be final. Later notification of such claims shall not bar the Contractor's claim unless the State is prejudiced by the delay in notification. No claim by the Contractor for an adjustment hereunder shall be allowed if notice is not given before final payment under this contract. Any adjustment in the contract price made pursuant to this clause shall be determined according to Section 4.5 - Price Adjustment.

The provisions of this Section shall not be construed as establishing any claims contrary to the terms of Section 4.4 - Changes and Claims for Adjustment.

Nothing herein contained, however, shall excuse the Contractor from compliance with any rules of law precluding any state officers and any Contractors from acting in collusion or bad faith in issuing or performing contract change orders which are clearly not within the scope of the contract.

SECTION 6 - CONTROL OF MATERIAL AND EQUIPMENT

6.1 DEFECTIVE MATERIALS - All materials not conforming to the requirements of these specifications or the special provisions shall be considered defective and all such materials, whether in place or not, shall be rejected. They shall be removed immediately from the site of the work, unless otherwise permitted by the Director. No rejected materials, the defects of which have been subsequently corrected, shall be used until approval in writing has been given by the Director. Upon failure on the part of the Contractor to comply promptly with any order to remove and replace defective materials, the Director may remove and replace defective material and to deduct the cost of removal and replacement from any monies due or to become due the Contractor.

6.2 TRADE NAMES AND ALTERNATES - For convenience in designation on the plans or in the specifications, certain equipment or articles or materials may be designated under a trade name or the name of a manufacturer and its information catalogue. The use of alternate equipment or an article or material which is of equal quality and of the required characteristics for the purposes intended will be permitted, subject to the written approval of the Director, in accordance with the following requirements:

A. QUALIFICATION BEFORE BID OPENING - When the specifications and/or plans specify one or more manufacturer's brand names of materials or equipment to indicate a quality, style, appearance, or performance, the bidder will be assumed to have based its bid on one of the specified named products, except where such proprietary product are specified, alternate brands may be qualified if found equal or better by the Director. Bidders requesting qualification of alternate proprietary products must submit a request to the Director for review and approval at the earliest date possible, but in any event, such request must be received at the Contracts office not later than ten (10) days before the bid opening date, not including the bid opening date.

It shall be the responsibility of the bidder to submit sufficient evidence based upon which a determination can be made by the Director that the alternate brand is qualified. The evidence shall be transmitted with a covering letter which shall list the evidence submitted and the items for which the substitution is requested.

If the evidence accompanying a request for substitution is insufficient to qualify a particular

model, the request shall be denied provided that further evidence may be submitted to qualify the item five (5) days prior to the bid opening date if the initial request was made prior to the deadline set above.

B. SUBSTITUTION AFTER BID OPENING - Substitution of material or equipment will not be allowed after the bid opening date except under the following unforeseen circumstances:

1. If a specified or pre qualified item is delayed by a lengthy strike in the factory or other unforeseeable contingency beyond the control of the Contractor which would cause an abnormal delay in the project completion.
2. If a specified or pre qualified item is found to be unusable due to change or other circumstances.
3. If the Contractor is willing to provide a more recently developed or manufactured item of material or equipment of the same manufacturer which the Director determines to be equal or better than the one specified or pre-qualified.

A substitution request, regardless of reason, shall be fully explained in writing by the Contractor and shall include its justification for said request, the quantities and unit prices involved, quotations and such other documents as are deemed necessary to support the request. Any savings in cost will accrue to the State and any additional cost for the substituted items will be paid by the Contractor.

The burden of proof as to the comparative quality and suitability of alternate equipment, articles, or materials shall be upon the bidder or Contractor and bidder or Contractor shall furnish, at its own expense, all information necessary or related thereto as required by the Director. The Director shall be the sole judge as to the comparative quality and suitability of alternate equipment, articles or materials and the Director's decisions shall be final.

The above shall not be construed to mean that substitution for brand name specified materials and equipment will be allowed; the Director reserves the right to deny any request he deems irregular or not in the best interest of the State.

6.3 ASSIGNMENT OF ANTITRUST CLAIMS FOR OVERCHARGES FOR GOODS AND MATERIALS PURCHASED

A. Vendor and purchaser recognize that in actual economic practice, overcharges resulting from antitrust violations are in fact usually borne by the purchaser. Therefore, vendor hereby assigns to purchaser any and all claims for such overcharges as to goods and materials purchased in connection with this order or contract, except as to overcharges which result from antitrust violations commencing after the price is established under this order or contract and which are not passed on to the purchaser under an escalation clause.

B. Contractor and owner recognize that in actual economic practice, overcharges resulting from antitrust violations are in fact usually borne by the owner. Therefore, contractor hereby assigns to owner any and all claims for such overcharges as to goods and materials purchased in connection with this order or contract, except as to overcharges which result from antitrust violations commencing after the price is established under this order or contract and any change order. In addition, contractor warrants and represents that each of its first tier suppliers and subcontractors shall assign any and all such claims to owner, subject to the aforementioned exception.

SECTION 7 - LEGAL RELATIONS AND RESPONSIBILITY

7.1 LAWS TO BE OBSERVED - The Contractor shall comply with all federal, state, city and county laws, ordinances, rules and regulations which in any manner affect those engaged or employed in the work, the materials used in the work, and the conduct of the work. Any reference to such laws, ordinances, rules and regulations shall include any amendments thereto effective as of the date of the call for sealed proposals.

The Contractor shall hold harmless, indemnify, defend and where appropriate, insure the State, its officers, agents and employees against any claim or liability arising from or based on the violation of any such laws, ordinances, rules or regulations. If any discrepancy or inconsistency is discovered in the contract for the work in relation to any law, ordinance, rule, regulation, order or decree, the Contractor shall forthwith report the same to the Director in writing.

7.2 PERMITS AND LICENSES - The Contractor shall procure all permits and licenses, pay all charges and fees, and give all notices necessary and incident to the due and lawful prosecution of the work.

7.3 PATENTS - The Contractor shall assume all costs arising from the use of patented materials, equipment, devices, or processes used on or incorporated in the work, and shall hold harmless, indemnify, defend and where appropriate, insure the State, its officers, agents and employees from all suits at law or actions of every nature, for or on account of the use of any patented materials, equipment, devices or processes.

7.4 RESPONSIBILITY FOR INJURY AND DAMAGE - The State, its officers, agents and employees shall not be held accountable in any manner for any loss or damage to the work or any part thereof, or for any of the materials and equipment used or employed in performing the work, or for any injury to any person or persons either workers or the public, or for any damage to property caused by the Contractor or its workers or any one employed by the Contractor. The Contractor shall be responsible for any liability imposed by law for any injury to any person or any damage to property resulting from defects or obstructions or from any cause whatsoever during the progress of the work or at any time before its completion and final acceptance. The acceptance of the completed work of the Contractor by the Director shall not relieve the Contractor from any liability which may have accrued or may accrue as a result of the performance of the work by the Contractor. The Contractor shall hold harmless, indemnify, defend and where appropriate, insure the State, its officers, agents and employees, from all suits or actions of every name, kind and description, brought for or on account of

any injuries or damages sustained by any persons or property caused by the Contractor, its servants or agents, or by or on account of any act or omission of the Contractor or its servants or agents, regardless of whether such actions or any claim is brought against them or any one of them before or after the final acceptance of the work. In addition to any remedy authorized by law, the State may withhold payment of any money due to Contractor as shall be reasonable until disposition has been made of any suits or claims for injuries or damages.

It is not the intention of the parties to this contract to make the public or any member thereof a third party beneficiary hereunder, or to authorize anyone not a party hereto to maintain a suit for personal injuries or property damage based on a contract theory of liability. In any event, the Contractor shall hold harmless, indemnify, defend and where appropriate, insure the State from suits and claims for personal injuries or property damage where such injuries or damage are caused by the negligent acts or omissions of the Contractor, its agents or employees.

7.5 COOPERATION BETWEEN CONTRACTORS - Where two or more Contractors are employed on related or adjacent work, each shall conduct its operations in such a manner as not to cause any unnecessary delay or hindrance to the other.

7.6 CONTRACTOR'S RESPONSIBILITY FOR WORK - Until the acceptance of the contract, the Contractor shall have the charge and care thereof and shall bear the risk of injury or damage to any part thereof by the action of the elements or from any other cause, whether arising from the execution or from the non-execution of the work. The Contractor shall rebuild, repair, restore, and make good all damages to any portion of the work occasioned by any of the above causes before its completion and acceptance and shall bear the expenses thereof.

7.7 NO PERSONAL LIABILITY - Neither the Director nor any other officer or authorized employee of the Department shall be personally responsible for any liability arising under the contract.

7.8 LABOR AND COMPENSATION REQUIREMENTS - Wages paid each laborer employed by the Contractor or any subcontractor shall not be less than the prevailing minimum wage rate prescribed by law.

Every laborer employed by the Contractor or any subcontractor whose rate of compensation is Five Dollars (\$5.00) or less per day shall be paid his wages weekly pursuant to Section 103-54, H.R.S.

The Contractor's attention is directed to Chapter 377, H.R.S., Hawaii Employment Relations Act; Chapter 378, H.R.S., Employment Practices; Chapter 383, H.R.S., Hawaii Employment Security Law; Chapter 386, H.R.S., Workers' Compensation Law; Chapter 387, H.R.S., Wage and Hour Law; Chapter 392, H.R.S., Temporary Disability Insurance; Chapter 393, H.R.S., Prepared Health Care Act; Chapter 396, H.R.S., Occupational Safety and Health; and Section 103-55, H.R.S., Wages, Hours, Working Conditions of Employees of Contractor's Supplying Services.

7.9 INSURANCE - Prior to commencing with the work, the Contractor shall, at its own expense, obtain and submit to the Department, Certificate of Insurance from an insurance company authorized by the laws of the State to issue such insurance in the State of Hawaii showing full policy coverage of the Contractor.

TYPES OF INSURANCE:

A. Workers' Compensation:

The Contractor shall obtain worker's compensation insurance for all persons whom they employ in carrying out the work under this contract. This insurance shall be in strict conformity with the requirements of the most current and applicable State of Hawaii Worker's Compensation Insurance laws in effect on the date of the execution of this contract and as modified during the duration of the contract. The minimum limit of liability for workers compensation is the HRS 386 statutory limit.

B. Comprehensive Automobile Liability:

The Contractor shall obtain Auto Liability Insurance covering all owned, non-owned and hired autos with a combined single Limit of not less than \$1,000,000 per accident for bodily injury and property damage with the State of Hawaii named as additional insured. The required limit of insurance may be provided by a single policy or with a combination of primary and excess

policies.

C. Commercial General Liability:

The Contractor shall obtain General Liability insurance with a limit of not less than \$1,000,000 per occurrence and in the aggregates. The General liability insurance shall include the State of Hawaii as an additional insured. The required limit of insurance may be provided by a single policy or with a combination of primary and excess policies.

All policies must provide that 30 days prior written notice of cancellation or material change in coverage be given to certificate holders stated above.

Such insurance when accepted by the Director in writing shall become applicable and shall remain unmodified throughout the entire term of the contract and in no event shall be terminated or otherwise allowed to lapse prior to written certification of final acceptance of the work by the State. Such insurance aforementioned shall cover the State for all work performed under the contract, all work performed incidental thereto or directly or indirectly connected therewith, including other work performed outside of the work area, and all change orders.

Any delay in the submission and approval of insurance certificates shall not be justification of or grounds for a request by the Contractor postponing the issuance of a notice to proceed notwithstanding the fact that the Contractor shall not be allowed to proceed with the work until said certificates are submitted and approved.

Failure to obtain insurance in accordance with the Section, on the part of the Contractor, shall be considered a major breach of the contract; and should the State be forced to expend funds which would have been covered under the insurance, the Contractor agrees to assume the liability for such funds and to indemnify and hold the State harmless.

SECTION 8 - PROSECUTION AND PROGRESS

8.1 NOTICE TO PROCEED - A "Notice to Proceed" letter will be written to the Contractor by the Director. Such letter will indicate the date the Contractor is to begin work and from which date the contract time will commence to run.

The Contractor shall diligently perform the required duties during the term of the contract, or if the work is to be completed within a specified time limit, the Contractor shall diligently prosecute the work to completion within the specified time limit.

8.2 SUBCONTRACTING - The Contractor shall give its personal attention to the fulfillment of the contract and shall keep the work under its control.

Subject to Section 103D-302, H.R.S., the Contractor may subcontract a portion of the work pursuant to the provisions of this section, but the Contractor shall be primarily responsible for the work so subcontracted. The Contractor shall not subcontract any work to any subcontractor who has been suspended by the State.

Before any work is started under a subcontract, the Contractor shall have the written approval of the Director on a written statement on forms furnished by the Department, indicating the work to be subcontracted, the names of the subcontractors and the description of each portion of the work to be so subcontracted and showing that the subcontractors are particularly experienced and equipped to do the work subcontracted. The Contractor shall give assurance that the minimum wage rate schedule as stated in the contract shall apply to labor performed on the work so subcontracted. Consent of the Director to the subcontracting of work shall not be construed to relieve the Contractor of any responsibility for the fulfillment of the contract.

When any portion of the work which has been subcontracted by the Contractor is not prosecuted in a manner satisfactory to the Director, the Contractor, upon receipt of a notice thereof in writing from the Director, shall remove the subcontractor immediately from the project and the subcontractor shall not again be employed on the work.

8.3 ASSIGNMENT OF CONTRACT - The performance of the contract may be assigned only with the prior written consent of the Director and when applicable, the Contractor's surety. Consent to any assignment shall not relieve the Contractor or the Contractor's surety of any obligations of the contract.

8.4 INSUBORDINATION - If any subcontractor or person employed by the Contractor shall fail or refuse to carry out the directions of the Director or shall appear to the Director to be incompetent or to act in a disorderly or improper manner, the subcontractor or person shall be removed immediately upon request by the Director and shall not again be employed on the work, nor shall it be employed upon any other Department project currently under contract to the same Contractor or subcontractor.

8.5 TEMPORARY SUSPENSION OF WORK

A. Order to stop work. The Director, may, by written order to the contractor, at any time, and without notice to any surety, require the contractor to stop all or any part of the work called for by this contract. This order shall be for a specified period not exceeding sixty (60) days after the order is delivered to the contractor, unless the parties agree to any further period. Any such order shall be identified specifically as a stop work order issued pursuant to this section. Upon receipt of such an order, the contractor shall forthwith comply with its terms and take all reasonable steps to minimize the occurrence of costs allocable to the work covered by the order during the period of work stoppage. Before the stop work order expires, or within any further period to which the parties shall have agreed, the Director shall either:

1. Cancel the stop work order; or
2. Terminate the work covered by such order as provided in the "termination for default clause" or the "termination for convenience clause" of this contract.

B. Cancellation or expiration of the order. If a stop work order issued under this section is canceled or if the period of the order or any extension thereof expires, the contractor shall have the right to resume work. An appropriate adjustment shall be made in the delivery schedule or contract price, or both, and the contract shall be modified in writing accordingly; if:

1. The stop work order results in an increase in the time required for, or in the contractor's cost properly allocable to, the performance of any part of this contract; and
2. The contractor asserts a claim for such an adjustment within thirty (30) days after the end of the period of work stoppage; provided that, if the Director decides that the facts justify such

action, any such claim asserted may be received and acted upon at any time prior to final payment under this contract.

C. Termination of stopped work. If a stop work order is not canceled and the work covered by such order is terminated for default or convenience, the reasonable costs resulting from the stop work order shall be allowable by adjustment or otherwise.

D. Adjustment of price. Any adjustment in contract price made pursuant to this clause shall be determined in accordance with the price adjustment clause of this contract.

8.6 LIQUIDATED DAMAGES - It is mutually understood and agreed by and between the parties to the contract that the performance by the Contractor of its duties every calendar/working day is an essential part of the contract and in case of failure on the part of the Contractor to perform its duties for the time specified in the contract, the State will be damaged thereby and the amounts of said damages being difficult, if not impossible of definite ascertainment and proof, shall be estimated, agreed upon and fixed at the sum shown in the proposal for each and every calendar/working day that the Contractor fails to perform its duties during the period the contract is in effect; and the Contractor shall pay the liquidated damages as provided for in the proposal and, in case the same are not paid, the Department may deduct the amount thereof from any monies due or that may become due the Contractor under the contract.

8.7 DEFAULT AND TERMINATION OF CONTRACT

A. Termination by Default. If the contractor refuses or fails to perform any of the provisions of this contract with such diligence as will ensure its completion within the time specified in this contract, or any extension thereof, otherwise fails to timely satisfy the contract provisions, or commits any other substantial breach of this contract, the Director may notify the contractor in writing of the delay or non-performance and if not cured in ten (10) days or any longer time specified in writing by the Director, such officer may terminate the contractor's right to proceed with the contract or such part of the contract as to which there has been delay or a failure to properly perform. In the event of termination in whole or in part the Director may procure similar goods or services in the manner and upon terms deemed appropriate by the Director. The contractor shall continue performance of the contract to the extent it is not terminated and shall be liable for excess costs incurred in procuring

similar goods or services.

1. Contractor's duties. Notwithstanding termination of the contract and subject to any directions from the Director, the contractor shall take timely, reasonable, and necessary action to protect and preserve property in the possession of the contractor in which the State or county has an interest.

2. Compensation. Payment for completed goods delivered and accepted by the State shall be at the contract price. Payment for the protection and preservation of property shall be in an amount agreed upon by the contractor and Director; if the parties fail to agree, the Director shall set an amount subject to the contractor's rights under chapter 3-126, HAR. The State may withhold from amounts due the contractor such sums as the Director deems to be necessary to protect the State against loss because of outstanding liens or claims of former lien holders and to reimburse the State for the excess costs incurred in procuring similar goods and services.

3. Excuse for nonperformance or delayed performance. Except with respect to defaults of subcontractors, the contractor shall not be in default by reason of any failure in performance of this contract in accordance with its terms, including any failure by the contractor to make progress in the prosecution of the work hereunder which endangers such performance, if the contractor has notified the Director within fifteen (15) days after the cause of the delay and the failure arises out of causes such as: acts of God; acts of the public enemy; acts of the State and any other governmental body in its sovereign or contractual capacity; fires; floods; epidemics; quarantine restrictions; strikes or other labor disputes; freight embargoes; or unusually severe weather. If the failure to perform is caused by the failure of a subcontractor to perform or to make progress, and if such failure arises out of causes similar to those set forth above, the contractor shall not be deemed to be in default, unless the goods or services to be furnished by the subcontractor were unreasonably obtained from other sources in sufficient time to permit the contractor to meet the contract requirements. Upon request of the contractor, the Director shall ascertain the facts and extent of such failure, and if such officer determines that any failure to perform was

occasioned by any one or more of the excusable causes, and that, but for the excusable cause, the contractor's progress and performance would have met the terms of the contract, the delivery schedule shall be revised accordingly, subject to the rights of the State under the clause entitled "Termination for Convenience". As used in this paragraph of this clause, the term "subcontractor" means subcontractor at any tier.

4. Erroneous termination for default. If, after notice of termination of the contractor's right to proceed under the provisions of this clause, it is determined for any reason that the contractor was not in default under the provisions of the clause, or that the delay was excusable under the provisions of paragraph 3 above, Excuse for nonperformance or delayed performance of this clause, the rights and obligations of the parties shall, if the contract contains a clause providing for termination for convenience of the State, be the same as if the notice of termination had been issued pursuant to such clause.

5. Additional rights and remedies. The rights and remedies provided in this clause are in addition to any other rights and remedies provided by law or under this contract.

B. Termination for convenience. The Director may, when the interests of the State so require, terminate this contract in whole or in part, for the convenience of the State. The Director shall give written notice of the termination to the contractor specifying the part of the contract terminated and when termination becomes effective.

1. Contractor's obligation. The contractor shall incur no further obligations in connection with the terminated work and on the dates set in the notice of termination the contractor will stop work to the extent specified. The contractor shall also terminate outstanding orders and subcontracts as they relate to the terminated work. The contractor shall settle the liabilities and claims arising out of the termination of subcontracts and orders connected with the terminated work. The Director may direct the contractor to assign the contractor's right, title, and interest under terminated orders or subcontracts to the State. The contractor must still complete the work not terminated by the notice of termination and may incur obligations as are necessary to do so.

2. Right to goods. The Director may require the contractor to transfer title and deliver to the State in the manner and to the extent directed by the Director:

- a. Any completed goods; and
- b. The partially completed goods and materials, parts, tools, dies, jigs, fixtures, plans, drawings, information, and contract rights hereinafter called "manufacturing material," as the contractor has specifically produced or specially acquired for the performance of the terminated part of this contract.

The Contractor shall, upon direction of the Director, protect and preserve property in the possession of the contractor in which the State has an interest. If the Director does not exercise this right, the contractor shall use the Contractor's best efforts to sell such goods and manufacturing materials. Use of this section in no way implies that the State has breached the contract by exercise of the termination for convenience clause.

3. Compensation:

- a. The Contractor shall submit a termination claim specifying the amounts due because of the termination for convenience together with cost or pricing data to the extent required by subchapter 15, chapter 3-122, HAR, bearing on such claim. If the Contractor fails to file a termination claim within one (1) year from the effective date of termination, the Director may pay the Contractor, if at all, an amount set in accordance with subparagraph c. below.
- b. The Director and the Contractor may agree to settlement provided the Contractor has filed a termination claim supported by cost or pricing data to the extent required by subchapter 15, chapter 3-122, HAR, and that the settlement does not exceed the total contract price plus settlement costs reduced by payments previously made by the State, the proceeds of any sales of goods and manufacturing materials under paragraph (2) of this clause, and the contract price of the work not terminated.

c. Absent complete agreement under subparagraph b above, the Director shall pay the Contractor the following amounts, provided payments agreed to under subparagraph b shall not duplicate payments under this subparagraph for the following:

(i) Contract prices for goods or services accepted under the contract;

(ii) Costs incurred in preparing to perform and performing the terminated portion of the work plus a fair and reasonable profit on such portion of the work, such profit shall not include anticipatory profit or consequential damages, less amounts paid or to be paid for accepted goods or services; provided that if it appears that the Contractor would have sustained a loss if the entire contract would have been completed, no profit shall be allowed or included and the amount of compensation shall be reduced to reflect the anticipated rate of loss;

(iii) Costs of settling and paying claims arising out of the termination of subcontracts or orders pursuant to paragraph 1 of this clause. These costs must not include costs paid in accordance with subparagraph (ii) above.

(iv) The reasonable settlement costs of the Contractor including accounting, legal, clerical, and other expenses reasonably necessary for the preparation of settlement claims and supporting data with respect to the terminated portion of the contract and for the termination of subcontracts thereunder, together with reasonable storage, transportation, and other costs incurred in connection with the protection or disposition of property allocable to the terminated portion of this contract. The total sum to be paid the Contractor under this subparagraph shall not exceed the total contract price plus the reasonable settlement cost of the Contractor reduced by the amount of payments otherwise made, the proceeds of any sales of supplies and manufacturing materials under subparagraph b of this paragraph, and the contract price of work not terminated.

d. Cost claimed, agreed to, or established under subparagraphs b and c shall be in accordance with chapter 3-123, HAR. bearing on such claim.

8.8 FINAL INSPECTION - Upon notice from the Contractor of the completion of the work or contract, the Director shall make an inspection. If the contract is found completed to the Director's satisfaction, such inspection shall constitute the final inspection and acceptance of the work.

If the work is unsatisfactory in whole or in part, the Director shall notify the Contractor of the work necessary for final completion and acceptance and the Contractor shall forthwith perform the work required by the Director. Upon performance of such required work by the Contractor, another inspection shall be made which shall constitute the final inspection if the work is completed satisfactorily.

Within ten (10) days after final inspection and acceptance of the work, or as soon thereafter as is practicable, the Contractor shall be notified by the Director in writing of such acceptance.

8.9 TERMINATION OF CONTRACTOR'S RESPONSIBILITY - The contract will be considered complete when all work has been completed, the final inspection made, the work accepted by the Director, and the final estimate paid. The Contractor will then be released from further obligation except as set forth in the contract and bond, when applicable.

SECTION 9 - PAYMENT

9.1 SCOPE OF PAYMENT - The Contractor's bid price shall be inclusive of all costs, direct or indirect, including all taxes, required for the fulfillment of the contract.

Contract payments to the Contractor by the State shall be full payment for the furnishing of all labor, tools, equipment, and other incidentals, including all taxes, necessary for performing all work and services contemplated and embraced under the contract.

9.2 RETAINAGE/DEDUCTION FROM PAYMENT - The Director may at any time retain or deduct out of any sums due the Contractor to cover claims of the State against the Contractor, or such sums sufficient to cover any unpaid claims of others supported by sworn statements filed in the office of the Director, without any liability for damages, interest or otherwise to the Contractor for such retention or deduction.

Provided the work of the Contractor is progressing satisfactorily in the judgment of the Director and in accordance with the provisions of this contract, monthly payments, less five percent (5%), will be made to the Contractor. The amount of such monthly payments shall be determined by the Director based on the Director's estimate of the items of work performed and materials incorporated in the work and the value therefor at the unit prices or lump sum prices set forth in the contract. All monthly payments are shall be subject to correction at any time prior to or in the final payment.

At any time after fifty per cent (50%) of the work has been completed, if the State determines that the work contracted to be performed is progressing satisfactorily, the State may make any of the remaining monthly payments in full.

If the Director finds that unsatisfactory progress is being made, the State may, from the beginning of such unsatisfactory progress, withhold any amount up to five per cent (5%) of any subsequent monthly payment.

9.3 ASSIGNMENT OF PAYMENTS - All monies payable under the contract, or any part thereof, shall be paid to the Contractor in accordance with the provisions of this Section and no assignment or order executed by the Contractor directing payment of any portion or all of such funds to any other person or persons shall be recognized by the State unless such assignment or order specifies the amounts to be so paid and the purposes for which the assignment or order is given. Such assignment or order shall have attached thereto, by endorsement or otherwise, the consent of the surety, when

applicable. No such assignment or order shall be binding on the State.

Any assignment of money shall, however, be subject to all proper set-offs in favor of the State, to all deductions provided for in the contract and to all liens and rights conferred by law on the State. All money withheld, whether assigned or not, shall be subject to being used by the State for the completion of the work in the event of the Contractor's default.

9.4 PROGRESS PAYMENTS - Payments under this contract shall be made only upon submission by the Contractor of an original invoice and 2 copies. The invoice shall specify the amount due less retainage and shall also certify that services requested under the contract have been performed by the Contractor according to the contract.

9.5 FINAL PAYMENT - Final payment will only be made after the Contractor receives final acceptance by the Director as provided in Section 8.8, and until the Contractor has filed with the Department the following:

A. Consent of the surety, when applicable, to payment of the final estimate;

B. Satisfactory evidence by affidavit that all debts resulting from the contract have been fully paid or satisfactorily secured;

C. A current "Certificate of Vendor Compliance" issued by the Hawaii Compliance Express (HCE). The Certificate of Vendor Compliance is used to certify the Contractor's compliance with (a) Section 103D-328, HRS (for all contracts \$25,000 or more) which requires a current tax clearance certificate issued by the Hawaii State Department of Taxation and the Internal Revenue Service; (b) Chapters 383, 386, 392, and 393, HRS; and (c) Subsection 103D-310(c), HRS. The State reserves the right to verify that compliance is current prior to the issuance of final payment. Contractors are advised that non-compliance status will result in final payment being withheld until compliance is attained.

The filing of willfully false affidavits will disqualify the Contractor from bidding on future work of the Department.

SECTION 10 - FIRE EXTINGUISHER, FIRE HOSE, FIRE EXTINGUISHING
SYSTEMS AND AUTOMATIC FIRE SPRINKLER SYSTEMS TEST, INSPECTION
AND MAINTENANCE SERVICES

- 10.1 GENERAL - All work is subject to the requirements of Sections 1 to 9 inclusive, and this Section 10.

The Contractor shall make a complete examination of this document and in submitting a proposal, the Contractor shall claim to doing as such, as well as, further stating that they are:

- A. Qualified and experienced to comply with the Qualification requirements of these specifications.
- B. Understand the contracted services to be fulfilled as described in the Scope of Work.
- C. Thoroughly experienced with the Fire Protection Systems of same type as that of Daniel K. Inouye International Airport (HNL), Dillingham Airfield (HDH), and Kalaeloa Airport (JRF). consisting of items as listed in Appendix A and Proposal Schedules A thru F, including compliance requirements for each item listed.

- 10.2 SCOPE OF WORK - The work to be performed under this contract includes inspection, testing, maintenance, and replacement or correction as needed of the fire extinguishing systems for buildings and structures. Services shall include furnishing of all labor, supervision, materials, supplies, equipment and related items necessary to make any corrections necessary to maintain the system in proper operation; recurring work such as inspection, testing, and maintenance; and an allowance for the replacement of quantities of consumable products as specified for Daniel K. Inouye International Airport (HNL), Dillingham Airfield (HDH), and Kalaeloa Airport (JRF).

- A. The fire protection system covered include:
 - 1. Wet pipe
 - 2. Wet pipe automatic sprinkler systems, including Tamper and Flow switches
 - 3. Water spray systems
 - 4. Wet and Dry Standpipe systems
 - 5. Fire pumps

6. Clean Agent Fire Protection Systems
7. Fire Protection Deluge water tanks
8. Halon systems
9. Fire Hoses and Cabinets
10. Maintenance of portable Dry chemical fire extinguishers systems
11. Semi-Annual Operational Testing, Annual Inspection and the submission of inspection reports acceptable to the Authority Having Jurisdiction of each airport:
12. Complete and updated annual fire protection system inventory lists (to be submitted with annual testing reports) to include the following information for each item listed:
 - a. Manufacturer
 - b. Model Number
 - c. Part Number,
 - d. Item description (to include classification, size, type, condition, etc.)
 - e. Compliance inspections/testing and dates (to include date of manufacture, compliance inspection/testing, and replacement date, etc.)
 - f. Major repairs done within the last year.

B. The following fire suppression system related services are not inclusive to this contract:

1. Maintenance of public or airport water distribution systems
2. Maintenance of fire resistant assemblies
3. Maintenance of Fire Alarm Systems beyond the termination to Fire Protection System Monitoring Tamper or Flow Switch devices.

C. The Contractor shall:

1. Provide all work and services that required to be performed to keep the Fire Protection Systems functioning and in compliance in the manner that they are designed to function at all times, and shall be considered as incidental to the scope of this contract

- a. Except while being serviced as per Equipment manufacturer's recommendations and within their performance specifications.
2. At all times Certificates of compliance shall be current and ready for inspection for following:
 - National Fire Protection Association (NFPA) standards (as applicable)
 - All other laws, statutes, ordinances, fire codes, rules and regulations of the Federal, State and County governments and their respective departments or agencies.

Contractor shall maintain a ready copy of all documentation certifying it's compliance in a manner acceptable to the Authority Having Jurisdiction, originals to be bound and submitted to the State annually prior to contract renewal or final payment.

3. The Contractor shall replace necessary parts of the Fire Protection Systems which are worn through normal wear and tear at no cost to the State, except as described in Section 10.11 - REPLACEMENT AND RECHARGE OF EQUIPMENT. Labor costs for removing old parts and replacing with new during the course of inspection and maintenance services shall be considered incidental to the Contractor's bid prices and no additional payment will be made by the State. See Appendix A and Proposal Schedule A thru F for Equipment Lists.
4. The Contractor shall also submit to the State within thirty (30) days of Notice to Proceed of any discrepancies in list of State owned Fire Protection System items to be serviced and maintained of Proposal Schedule A thru F, to include but not be limited to:
 1. Additional items
 2. Condition and/or Compliance Status, or Information provided affecting its servicing schedule.

The State shall review discrepancy list provided for determination of how to address the situation.

Should the State determine additional item(s) are required to be added to the contracted Fire Protection Maintenance Services in place, the Contractor shall agree to use bid Unit-Prices for Like-Item as fair compensation to amend contract to include item(s) in within the contracted services, subject to the contracts availability of funds.

- D. All maintenance work shall be in compliance with current National Fire Protection Association (NFPA) standards (as applicable) and all other laws, statutes, ordinances, fire codes, rules and regulations of the Federal, State and County governments and their respective departments or agencies. Contractor shall be responsible to maintain and ensure all Fire Protection Equipment, including portable fire extinguishers, fire hoses and automatic fire protection systems (chemical and water) as listed in Appendix A and Proposal Schedule A thru F are maintained:
1. As per equipment manufacturer's recommendations
 2. Are at all times in a condition within normal operational parameters as specified by the equipment manufacturer.
 3. Certified to be of acceptable to the authority having jurisdiction at all times.

10.3 SPECIAL PERSONNEL SKILL AND QUALIFICATIONS

- A. Personnel assigned to conduct work under this contract shall have minimum five (5) years journeyman experience in the testing, maintenance and servicing of fire extinguishers, hoses and automatic fire sprinkler systems.
- B. Tests and inspections shall be conducted by a person having a valid certificate issued by the each respective airport's County Fire Department having jurisdiction, and licensed by the State of Hawaii to perform and certifying all work and testing required by this contract.
- C. All prospective bidders must be able to produce documented maintenance experience records upon request

to substantiate experience claims as prescribed herein.

- D. The Contractor shall have a State of Hawaii Specialty Contractor's "C-20" License at the time of bidding.
- E. Falsification of qualifications shall constitute a major breach of this contract.

10.4 SERVICE FACILITIES AND EQUIPMENT REQUIREMENTS - Any Contractor engaged in the servicing of portable fire extinguishers shall meet the minimum equipment and facilities requirements of NFPA 10 and all other laws, statutes, ordinances, fire codes, rules and regulations of the Federal, State and County governments and their respective departments or agencies.

10.5 PERFORMANCE OF WORK

- A. The Contractor shall perform inspection test and maintenance services on all State-owned fire extinguishers, fire hoses, and fire sprinkler systems including their operating and control system components, which have been installed at HNL, HDH and JRF and in accordance with such industrial practices and standards as established by the NFPA, and applicable governmental agencies, to provide assurance of safety and operational reliability.
- B. Within thirty (30) days after award of this contract, the Contractor shall submit to the Airport Engineer, in writing, a proposed schedule for inspection, test and preventive maintenance and an appropriate maintenance records system, all in sufficient detail to show its adequacy in carrying out the terms of this contract.
- C. The term "normal working days" as used herein shall mean between the hours of 7:00 a.m. and 3:30 p.m. or any 8 hour time period agreed upon between the contractor and State, Monday through Friday, State holidays excluded.
- D. The Contractor shall record all malfunctions and note necessary corrective actions required on the equipment in performing the work under this contract and shall provide the Airport Engineer with all such records

immediately after completion of maintenance tasks. Specific work except as noted in Sections 10.6, shall not be conducted until written approval is given by the Airport Engineer. In addition, a certification of inspection will be submitted along with each monthly check detailing the location, type, identification, size, make and servicing required for each fire extinguisher; the location, identification and servicing of all fire hoses and reels; and the location, identification, type and servicing of all fire sprinkler systems. A general condition report of any equipment serviced, all deficiencies or required corrective actions shall be reported to the Airport Engineer in accordance with NFPA and local standards.

- E. Monthly inspections shall be performed in the first week of the month on normal working days and must be coordinated with the Airport Engineer at least 24 hours in advance of scheduled inspection date.
- F. Quarterly inspections shall be performed in conjunction with monthly inspections when due on normal working days and must be coordinated with the Airport Engineer at least seven (7) days in advance of scheduled inspection date.
- G. Semi-annual inspection, tests and maintenance services shall be performed in the first and seventh month of each year of this contract on normal working days and must be coordinated with the Airport Engineer at least seven (7) days in advance of scheduled inspection date.
- H. Annual inspection, tests and maintenance services shall be performed in the first month of each year of this contract on normal working days and must be coordinated with the Airport Engineer at least seven (7) days in advance of scheduled inspection date.
- I. The Contractor shall report to the Airport Engineer prior to and after completing any work at the airport.
- J. All work performed by the Contractor will be subject to inspection by a representative of the Airports Division, State of Hawaii.

10.6 INSPECTION SERVICES - MONTHLY

- A. Fire Extinguisher Units - Inspection of fire extinguisher units shall be conducted in accordance to guidelines and procedures established under NFPA No. 10 and 101 and local ordinances. There will be a total of 11 monthly inspections with the 12th month performed as part of the annual inspection.
1. Check to see if unit is properly located in designated space and that there is no obstruction to access or visibility;
 2. Check to see if pressure gauge reading or indicator is in the operable range or position and confirm fullness by weighing or "hefting";
 3. Check unit for tampering, physical damage, corrosion or other impairment(s), including legible operating instructions;
 4. Check unit cabinet for tampering, physical damage, or other impairment(s), including legible labels;
 5. Punch tag, file monthly report in accordance with local ordinances and update and send completion summary to the Airport Engineer;
 6. For wheeled units, check the conditions of the tires, wheels, carriage, hose and nozzle; and
 7. If unit needs a blowdown, hydro-test, or needs to be replaced, the Airport Engineer is to be notified immediately. Corrective measure is not to be taken without the prior approval of the Airport Engineer.

10.7 MAINTENANCE INSPECTION - QUARTERLY

All fire sprinkler alarm devices shall be tested in accordance with NFPA 25 and local ordinances. There shall be a total of 3 quarterly inspections with the 4th quarterly inspection as part of the annual inspection. All valves should be exercised. Completion summary report shall be sent to the Airport Engineer.

10.8 INSPECTION - SEMI-ANNUAL

- A. Halon 1301 Systems - Inspection, maintenance and testing of Halon 1301 fire extinguisher systems shall be conducted in accordance with guidelines and procedures established under NFPA 12A and local ordinances. There will be a total of 2 semi-annual inspections. Send completion summary to Airport Engineer.
1. Check the agent quantity by weight and pressure of refillable containers.
 2. Record weight and pressure of the containers on tag attached to containers.
 3. Visually inspect Halon 1301 cylinders for any signs of damage.
 4. Visually inspect system hoses for any signs of damage.
 5. Thoroughly inspect the halon-protected enclosure to determine if penetrations or other changes have occurred that could result in halon leakage.
 6. Check if all output devices are functioning properly by depressing alarm test switch.
- B. Clean Agent Systems - Inspection, maintenance, and testing of Clean Agent fire extinguishing systems shall be conducted in accordance with NFPA 2001 and local ordinances. There will be a total of 2 semi-annual inspections. Send completion summary to Airport Engineer.
1. Check the agent quantity by weight and pressure of refillable containers.
 2. Record weight and pressure of the containers on tag attached to containers.
 3. Visually inspect Clean Agent cylinders for any signs of damage.
 4. Visually inspect system hoses for any signs of damage.

5. Thoroughly inspect the halon-protected enclosure to determine if penetrations or other changes have occurred that could result in halon leakage.
6. Check if all output devices are functioning properly by depressing alarm test switch.

10.9 MAINTENANCE INSPECTION - ANNUAL

A. Fire Extinguisher Units - In addition to all items established for monthly inspection, the annual maintenance inspection shall include:

1. Weighing, disconnect and blowout of all hoses and/or nozzles and valve checks for corrosion.
2. Pressure regulators provided with wheeled type fire extinguishers shall be tested for outlet static pressure and flow rate according to manufacturer's instructions.
3. In addition to the above, on wheeled units located on ramp areas, lubrication and the fluidization of powder (if needed) shall also be performed.
4. Annual inspection report, including the discrepancies and corrective action taken.

B. Fire Hoses and Cabinets - Inspection of fire hose units shall be conducted in accordance with guidelines and procedures established under NFPA 25, NFPA 1962 and local ordinances. The annual inspection shall include:

1. Visual inspection and check for tampering, physical damage, corrosion or other impairment.
2. Complete unwinding and hose blowout.
3. Valve operation test and check.
4. Flow-testing of wet standpipes.
5. Reel lubrication.
6. Annual inspection report, including the discrepancies and corrective action taken.

- C. Automatic Fire Sprinkler Systems - Annual certification inspection and tests, and maintenance service of all automatic fire extinguishing systems, including sprinkler alarm devices, shall be conducted in accordance with NFPA 25; City and County Fire Code of jurisdiction; and Hawaii Insurance Rating Bureau, Inc., flow test procedures. The annual inspection shall include:
1. Inspect, test and certify all automatic fire sprinkler systems.
 2. Inspect, test and verify operability of all Deluge automatic fire sprinkler systems.
 3. Riser flow tests:
 - a. Main drain
 - b. Gauge readings with valve wide open
 - c. Gauge static reading
 4. Visual inspection and checks for physical damage, tampering, impairment and conditions of the following:
 - a. Control Valves
 - (a) OS & Y
 - (b) Indicator post
 - (c) Underground gate valves with roadway box
 - b. Fire Department Connections
 - (a) Visible
 - (b) Caps
 - (c) Threads
 - (d) Drain
 - (e) Check valve
 - (f) Clear waterway
 - c. Hangers and Seismic Braces
 - d. Isolation Valves (Locations: 5 at basement level at Ewa Extension, 4 at basement level at

Main Terminal, and 3 at basement level at Diamond Head Extension.)

5. All valves shall be exercised.
 6. Annual inspection report including any discrepancies. Corrective measure is not to be taken without the prior approval of the Airport Engineer.
- D. Wet Standpipe System - Annual certification tests, inspection and maintenance service of all wet standpipe systems shall be conducted in accordance with NFPA 13, 14, and 25 and County Fire Codes of Jurisdiction and Test Procedures. The annual inspection shall include:
1. Inspect, test and certify wet standpipe systems.
 2. Flow test shall be required to be annually tested and documented by this contract (5 year required by code).
 3. Visual inspection for physical damage, tampering, impairment and condition of the following:
 - (a) Control valves
 - (b) Fire department connections
 4. Annual inspection report, including any discrepancies. Corrective measures are not to be taken without the prior approval of the Airport Engineer.
- E. Dry Standpipe Systems - Annual certification tests, inspection and maintenance service of all dry standpipe systems shall be conducted in accordance with NFPA 13, 14, and 25 and City & County Fire Codes of Jurisdiction and Test Procedures. The annual inspection shall include:
1. Inspect, test and certify three (3) dry standpipe systems.
 2. Air test system for leaks.
 3. Hydrostatic test system (5-year requirement).

4. Flow test (5-year requirement).
 5. Visual inspection for physical damage, tampering, impairment and condition of the following:
 - a. Control valves
 - b. Fire department connections
 6. Annual inspection report, including any discrepancies. Corrective measures are not to be taken without the prior approval of the Airport Engineer.
- F. Fire Pump Systems - Annual certification inspections, tests, and maintenance service of all fire pumps shall be conducted in accordance with NFPA 20, NFPA 25 and City and County Fire Codes of jurisdiction and Test Procedures. The annual inspection shall include:
1. Inspect, test and verify operability of Automatic Fire Pumps.
 2. Operability of all alarms.
 3. Verification of pressure relief valve:
 - a. Adjusted correctly
 - b. Set to relieve at the appropriate pressure.
 4. Verify operability of alternate power supply and automatic transfer switch if available.
 5. Inspect, test and certify Fire Pump Controllers and dividers if available.
 6. Visual inspection and checks for physical damage, tampering, impairment and conditions of the following:
 - a. Control Valves
 - (a) OS & Y
 - (b) Post indicator
 - (c) Underground gate valves with roadway box
 - b. Fire Department Connections

- (a) Visible
- (b) Caps
- (c) Threads
- (d) Drain
- (e) Check valve
- (f) Clear waterway

7. Annual inspection report including any discrepancies. Corrective measure is not to be taken without the prior approval of the Airport District Manager, State Project Manager or Airport Fire Chief.

10.10 MAINTENANCE SERVICES

- A. The Contractor's bid price shall include all labor, equipment, tools, taxes, insurance, overhead and all other incidentals necessary to complete the work to be done under this contract. The estimated number of replacement parts, recharges, refills and equipment tests as shown on the proposal is not to be construed as a minimum guarantee of the quantity to be furnished under this contract.
- B. The Contractor shall replace any extinguisher(s) removed for servicing with a comparable replacement unit at no cost to the State during the period of servicing. Any fire hose unit placed or deemed out of service shall be identified and clearly marked as being temporarily out of service or needs correcting. The Airport Engineer shall be advised any time a unit is removed or placed out of service, and when the unit is corrected, replaced or put back in service.
- C. The re-servicing/replacement of any damaged or discharged extinguisher, hose unit, cabinet, cabinet glass and locks, sprinkler heads, valves, etc. shall be accomplished as quickly as possible after notification by the Airport Engineer. Failure to correct, service or replace damaged and/or discharged units within the time limits imposed by his contract shall be grounds for the imposition of liquidated damages in the amounts and at the rates specified herein.

- D. Upon completion of each inspection, recharge or servicing, the Contractor shall leave the work area in a clean and safe condition. Equipment, supplies and materials used in conjunction with the work shall be cleared away, and the area(s) left in a clean and presentable manner. All fire fighting units are to be returned to their proper and assigned location(s).
- E. The Contractor shall provide appropriate labels, signs and decals for extinguishers and hose cabinets as required by codes.
- F. Before any fire extinguisher is to be discharged for blowdown and recharging, notification must be made to the Airport Engineer. Engineer has the option of discharging the fire extinguisher for training purposes.
- G. Coordination of all fire sprinkler system inspection, testing and corrections shall be made with the Fire Alarm System Contractor (FASC). Contact the Airport Engineer for the appropriate contact information for the FASC. Costs incurred by the FASC to disable and re-enable the alarm systems for inspection, testing and corrections needs to be pre-approved by the State and will be paid for by the State, not Contractor nor the FASC.

10.11 REPLACEMENT AND RECHARGE OF EQUIPMENT

- A. The Contractor shall provide work, parts, new replacement equipment, recharging, hydro-testing and other equipment testing at the prices bid in the proposal during the life of this contract. Any work not covered by items listed in the proposal shall be negotiated or put out to bid. All eliminated or replaced equipment shall be disposed of by Contractor.
- B. The bid item for the hydro-testing of fire extinguishers shall include in the bid item price the cost for recharging the fire extinguisher.
- C. The replacement and installation of missing and/or new equipment shall comply with the following instructions and specifications.

1. Fire Hose: 1-1/2" linen or rubber lined linen hose. Length shall be 100' or any other length suitable and approved by the Airport Fire Chief.
2. Recoupling: Recouple 1-1/2" booster hose using heavy duty brass couplings or equal with NST thread type. Adapters for connection with Pacific Coast threads shall be provided if needed. Couplings shall be affixed by using internal expansion ring. After coupling, hose shall be tested in accordance with NFPA 1962 (Care, Use and Maintenance of Fire Hose). Any couplings showing signs of slippage shall be cut off and recoupled. Any hose failing the test shall be so marked and returned for disposal. Hoses passing the test shall be marked in accordance with NFPA 1962 and placed back in service.
3. Hose Nozzle: For structural area hoses, plastic or equal.
4. Hose Cabinets (Building type): Cabinet shall be of rigid steel construction for surface mounting. The minimum size shall be 30" x 30" with steel door and with 6" x 6" break opaque glass and door opening fastened with full length piano hinge. The cabinet and door shall be of satin finish stainless steel, complete with LL24 lock or equal and key. Within 24 hours after installation, two duplicate keys for the hose cabinet lock shall be given to the Airport Engineer unless the Airport Engineer already has two master keys. The cabinets shall be installed over existing piping and valves by bolts and nuts and payment shall include installation. The cabinets shall be U/L approved.
5. Fire Extinguishers: Acceptable brands include Sentry, Strike, Kidde, Amerex, General, Ansul and any others approved by the Airport Engineer. All fire extinguishers shall be stenciled, "State of Hawaii - Airports Division", with white, black or yellow paint, whichever provides best visibility against the background color of the fire extinguisher.

6. Other Replacement Equipment: Other replacement equipment must be comparable to the equipment being replaced and suitable for the purpose intended. The Airport Engineer must approve of all equipment to be installed.
7. Reconditioning 150# Wheeled Fire Extinguisher: Units are to be emptied of chemical and thoroughly examined for defects in accordance with NFPA 10 (Portable Fire Extinguishers) and Compressed Gas Assm. Standard No. 6 (Visual Inspection of Compressed Gas Cylinders). Unit is to be disassembled and all parts sandblasted to bare metal, primed and refinished. Hydrostatic testing, if necessary, is to be accomplished after sandblasting and priming. Care is to be exercised to retouch any scratches in the finish.
 - a. Unit is to be recharged as per NFPA 10, tagged by a certified fire extinguisher repairer, and returned ready for service.
 - b. Paint Specifications:
 - c. Primer 1 coat zinc chromate primer (or equal)
 - d. Finish 2 coats heavy duty alkyd enamel

10.12 WORK SCHEDULE - The Contractor is required to sign in and out at the maintenance control office daily whenever it performs any work under this contract. Any work which is not properly documented and certified by an authorized State representative may not be compensated by the State.

The State reserves the right to provide the Contractor with preprinted maintenance worksheets to be completed by the Contractor.

- A. Regular Working Hours - The term "regular working hours" as used in these specifications shall mean 7:00 a.m. to 3:30 p.m., Monday through Friday, State holidays excluded. Conditions at the airport may require the Contractor to adjust their work schedule to cause the least amount of disruption to airport operations at no additional cost to the State.

- B. In case of mechanical failure or malfunction of the fire sprinkler system for any cause, the Contractor is subject to be called by the State. Should the Contractor be called during regular working hours, he shall respond within two (2) hours to the job site.
1. Trouble calls during regular working hours shall be paid for based on the hourly bid price in the Contractor's proposal multiplied by the time spent at the job site to complete the work.
 2. Time spent at the job site to complete the work during regular working hours shall be taken to the closest one-half (1/2) of an hour and any fraction of one-half (1/2) of an hour shall be considered a full one-half (1/2) of an hour.
 3. All trouble call tickets during regular working hours shall be certified and signed by an authorized representative of the Airport Engineer in order for the Contractor to receive payment therefore.
 4. Except as noted in Subsection 10.12 herein, the hourly bid price shall include all labor, materials, equipment, overhead, insurance, taxes, and all other incidentals necessary to complete the work.

For bidding purposes only, it is estimated there will be a total of 450 hours of corrective work as a result of trouble calls.

- C. Off-Hours Trouble Calls - The term "off-hours" as used in these specifications shall mean 3:30 p.m. to 7:00 a.m. the following morning, Monday through Friday; and 7:00 a.m. to 7:00 a.m. the following morning on Saturdays and Sundays. All time during State holidays shall be considered "off-hours".
1. If the Contractor is called by the State during off-hours to perform corrective work, the Contractor shall respond within four (4) hours to the job site. The off-hours hourly rate of pay shall be based on the hourly bid rate of the Contractor's proposal regular working hours

trouble calls plus fifty percent (50%) of the Contractor's hourly bid rate.

2. Except as noted in Subsection 10.12 herein, such off-hours hourly rate of pay shall include all labor, materials, equipment, overhead, insurance, taxes and other incidentals necessary to complete the corrective work.
3. For corrective work performed during off-hours, the Contractor shall be paid at the off-hours hourly rate multiplied by the time spent at the job site to complete the corrective work.
4. Time spent at the job site to complete work during off-hours shall be taken to the closest one-half (1/2) of an hour and any fraction of one-half (1/2) of an hour shall be considered a full one-half (1/2) of an hour. In any event, the Contractor shall receive a minimum of one (1) hour of pay even if the corrective work is completed in less than one (1) hour.
5. The Contractor shall secure the Airport Engineer's authorization for any work in excess of two (2) hours during off-hours. All off-hour trouble call tickets shall be certified and signed by an authorized representative of the Airport Engineer in order for the Contractor to receive payment therefore.
6. Corrective work initiated during off-hours and finished during regular working hours shall be paid accordingly. That is, off-hours hourly rate shall only apply to the work performed during off-hours, and regular working hours hourly rates shall apply for corrective work performed during regular working hours.

10.13 CORRECTION OF EQUIPMENT AND PARTS REPLACEMENT - If replacement of parts is required on any trouble call and / or if the replacement of parts is not covered under any specific provisions of this contract, the Contractor shall be reimbursed for the cost of the new parts excluding taxes, including shipping charges, plus 20% for overhead, profit, taxes and other incidental expenses. Labor cost will be charged at the Contract labor rate. The

Contractor shall substantiate his charges by submitting original material invoices and timesheets with his monthly billing.

Unless otherwise specifically provided for in the specifications, all equipment, materials, and articles incorporated in the work covered by this contract are to be new and of the most suitable grade for the usage intended and all workmanship shall be done in a workmanlike fashion class.

- 10.14 ADVISORY SERVICES AND SUBCONTRACTORS - All advisory services by the foreman or any other Contractor's personnel to the mechanics in performing their work shall be considered as incidental costs to the Contractor and included in the Contractor's hourly bid rate for regular working hours trouble calls. No separate payment shall be made therefore.

All specifications and hourly bid rates under this contract shall be applicable to subcontractor(s) should their services be required.

- 10.15 TERM OF CONTRACT - The term of this contract shall be for a one (1) year period beginning from the date indicated in the Notice to Proceed from the State unless renewed as provided for under Section 10.16.

- 10.16 OPTION TO EXTEND TERM - Subject to the availability of State funds, this contract may be extended by mutual agreement for two (2) additional one (1) year terms at the option of the State provided: 1) the option to extend is exercised by the State prior to expiration of the contract; 2) the term, including extensions, shall not exceed three (3) years; and 3) payment to the Contractor for each of the additional terms is based on the unit bid prices indicated in the Proposal Schedule of the original contract with no adjustments.

The Contractor is advised that a contract similar in all essentials to this contract may be advertised for bids by the State so that the bids will be received prior to the thirty (30) days before the expiration of this contract. The Contractor may submit a bid in response to such solicitation of bids upon compliance with the applicable requirements.



- 10.17 INSPECTION AND CORRECTION OF DEFECTS - All materials furnished and services performed by the Contractor under this contract shall be subject to inspection and test by the Director or his representative to the extent practical. Inspection of all places may be conducted unannounced and at any time of day or night. All inspections and tests by the Director shall be performed in such a manner as will not unduly delay or interrupt the Contractor's work.
- 10.18 SAFETY PRECAUTION -The Contractor will comply with all applicable safety regulations promulgated by the Occupational Safety and Health Administration (OSHA) and other governmental agencies.
- 10.19 MONTHLY INVOICES - Payment will be made to the Contractor at the contract unit price per service rendered as indicated in the Proposal Schedule. These prices shall be full compensation for furnishing all labor, materials, equipment, taxes and incidentals necessary to complete the work.

One original invoice and one copy shall be submitted to the State Project Manager and shall include a signed and completed maintenance service report, which includes a task / inspection / testing itemized checklist, and any completed trouble call tickets with its certifying State signature. Processing of the maintenance billing will not be started without this report.

STATE OF HAWAII
DEPARTMENT OF TRANSPORTATION
AIRPORTS

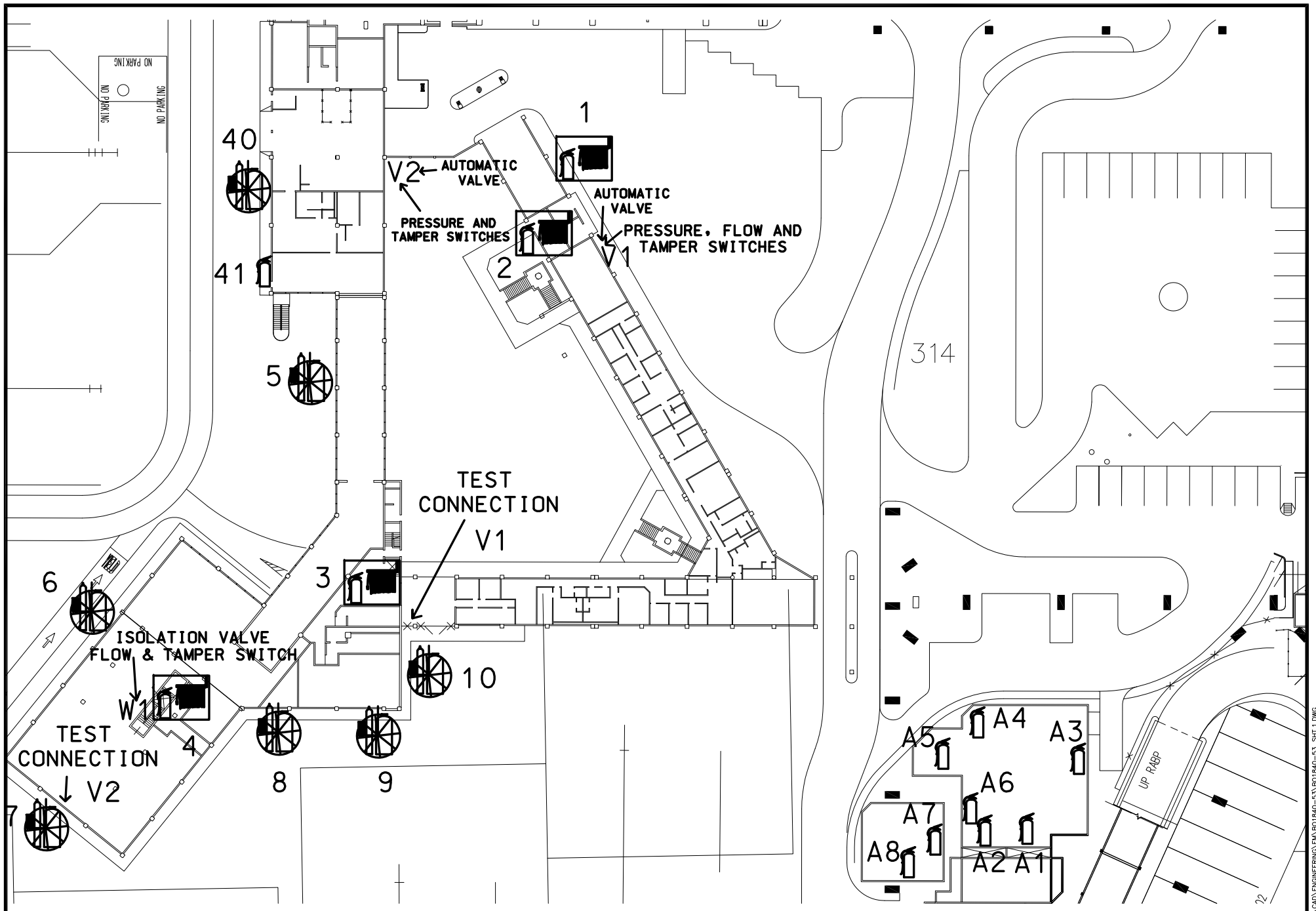
APPENDIX A



HONOLULU INTERNATIONAL AIRPORT  Airports Division		Date : FEBRUARY 2018	EXHIBIT:  SHT 1 OF 62
GROUND FLOOR - RAMP & PIER LOCATION		BO1542-43 Inspection and Maintenance of Airport Fire Protection Equipment	

H:\AIRPORTS\HNL_HONOLULU\CAD\ENGINEERING\EM\BO1540-53\BO1540-53_SHT.1.LWG

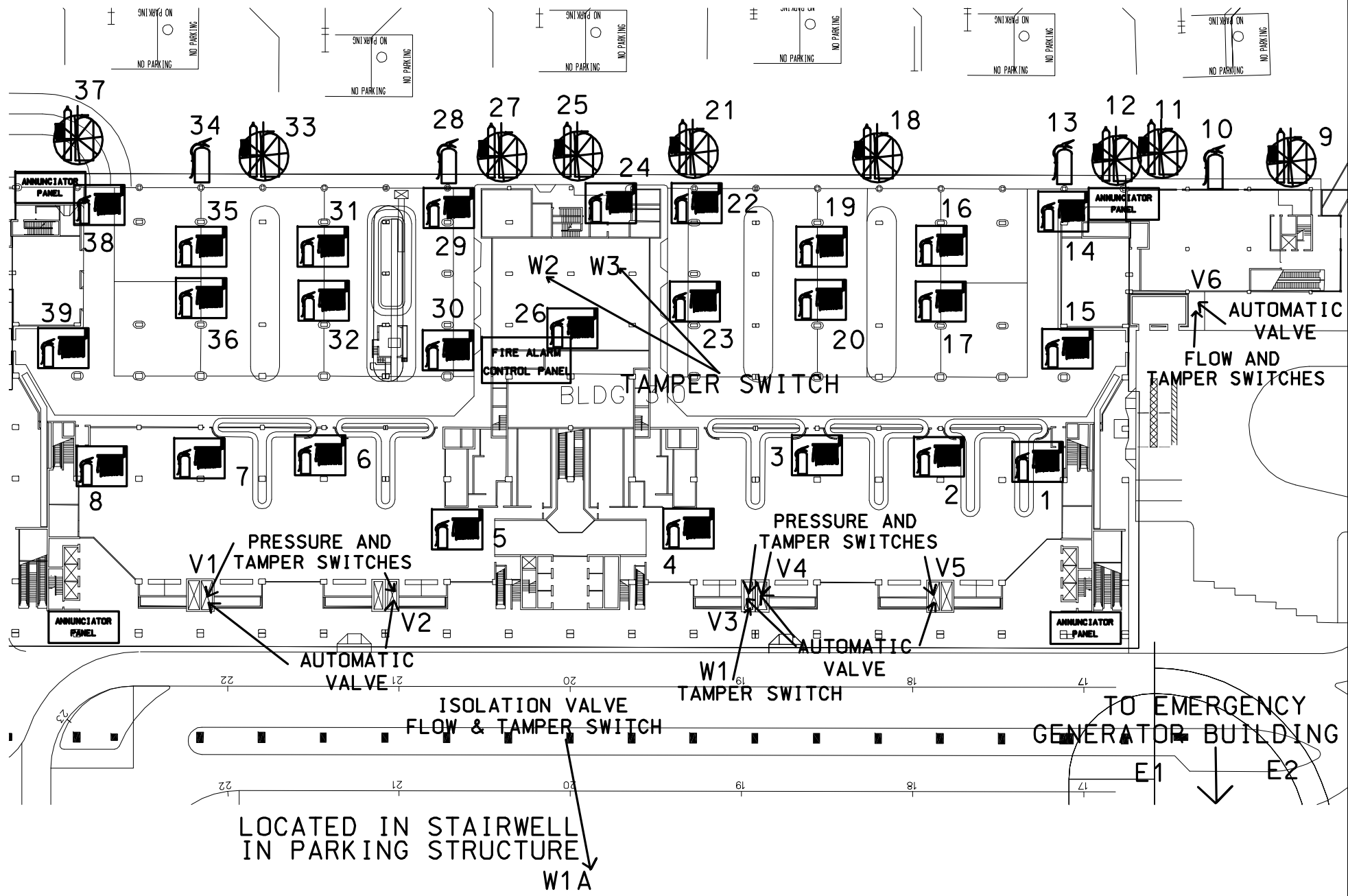

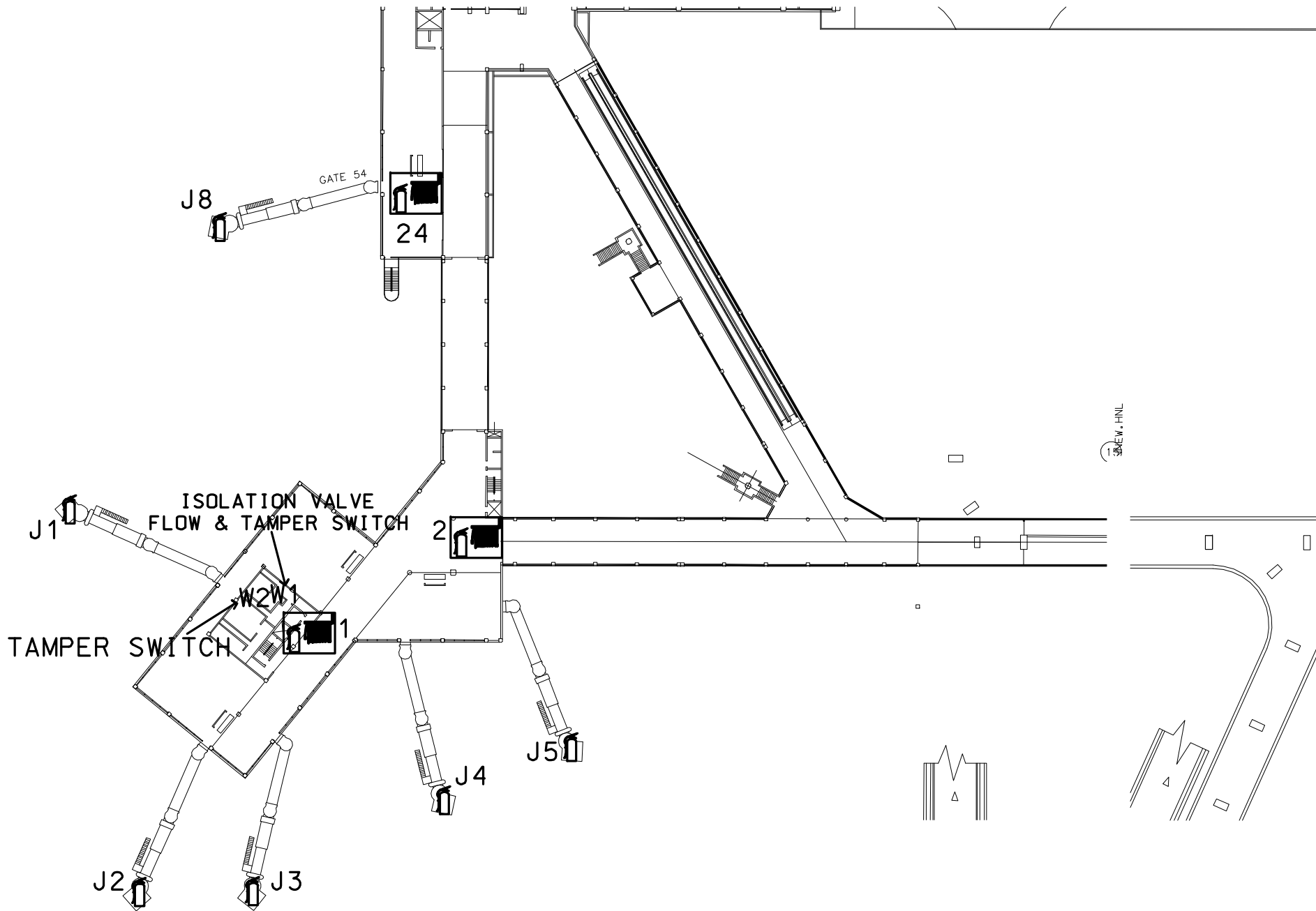

HONOLULU INTERNATIONAL AIRPORT  Airports Division		Date : FEBRUARY 2018	EXHIBIT: 
INTER-ISLAND TERMINAL - MAKAI PIER 2/F - DEPARTURE LOUNGE & LOADING BRIDGE LOCATION		BO1542-43 Inspection and Maintenance of Airport Fire Protection Equipment	SHT 3 OF 62

W:\AIRPORTS\HNL\HONOLULU\CAD\ENGINEERING\EM\BO1540-43\BO1540-43_SHT.3.DWG

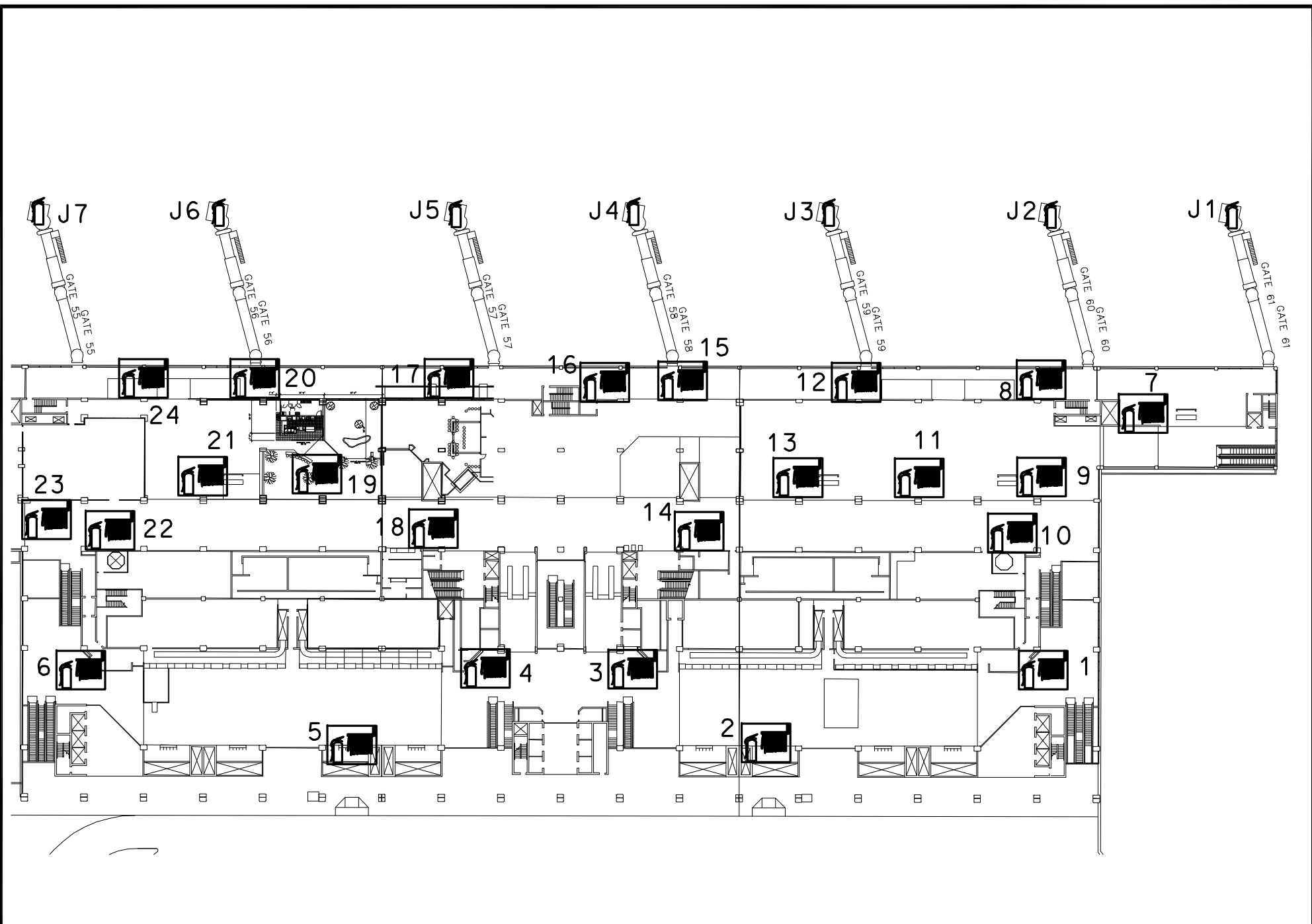

HONOLULU INTERNATIONAL AIRPORT  Airports Division		Date : FEBRUARY 2018	EXHIBIT: 
INTER-ISLAND TERMINAL - 2/F TICKETING, DEPARTURE LOUNGE & LOADING BRIDGE LOCATIONS		BO1542-43 Inspection and Maintenance of Airport Fire Protection Equipment	SHT 4 OF 62

W:\AIRPORTS\HNL_HONOLULU\CAD\ENGINEERING\EM\BO1540-53\BO1540-53_SHT_4.DWG

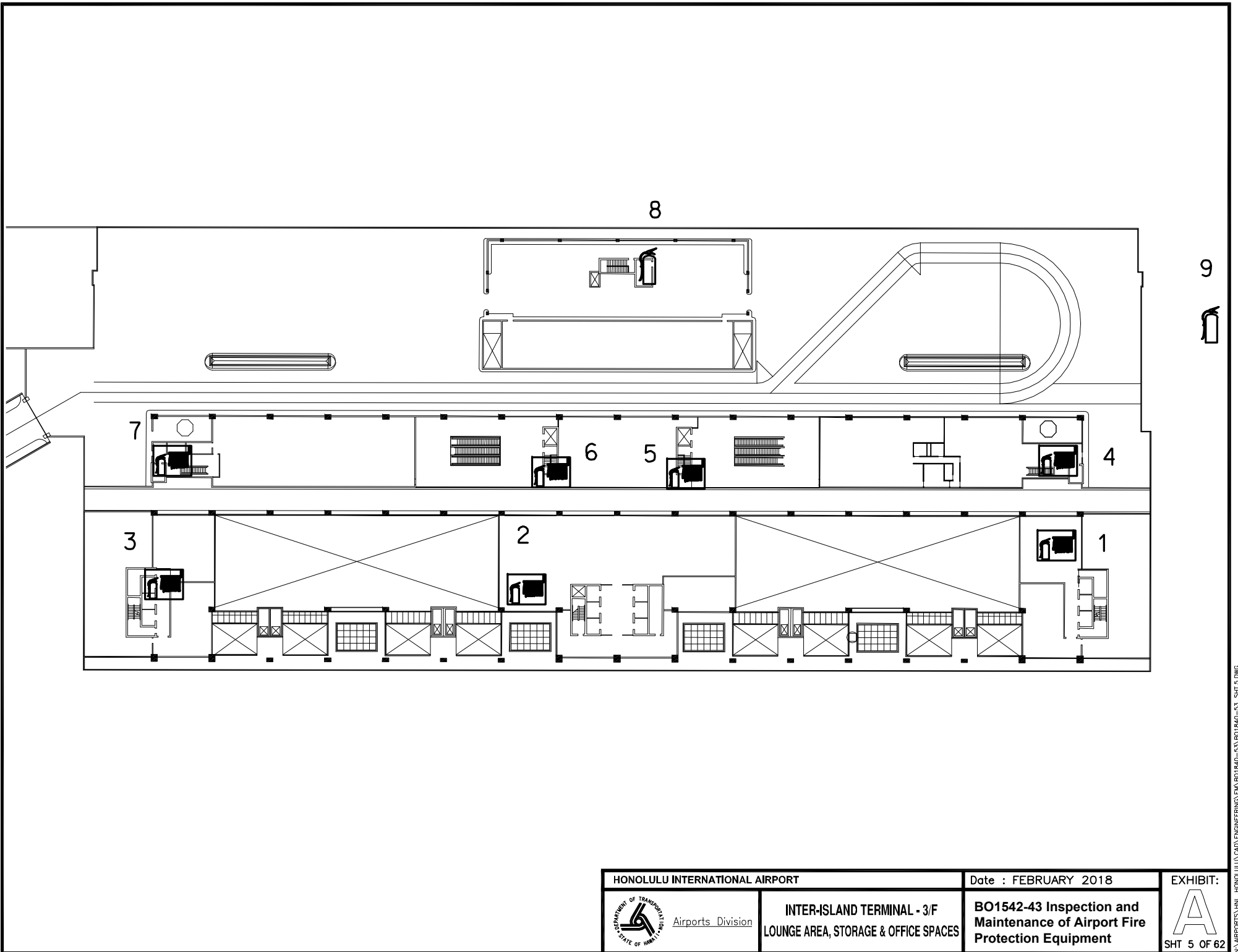

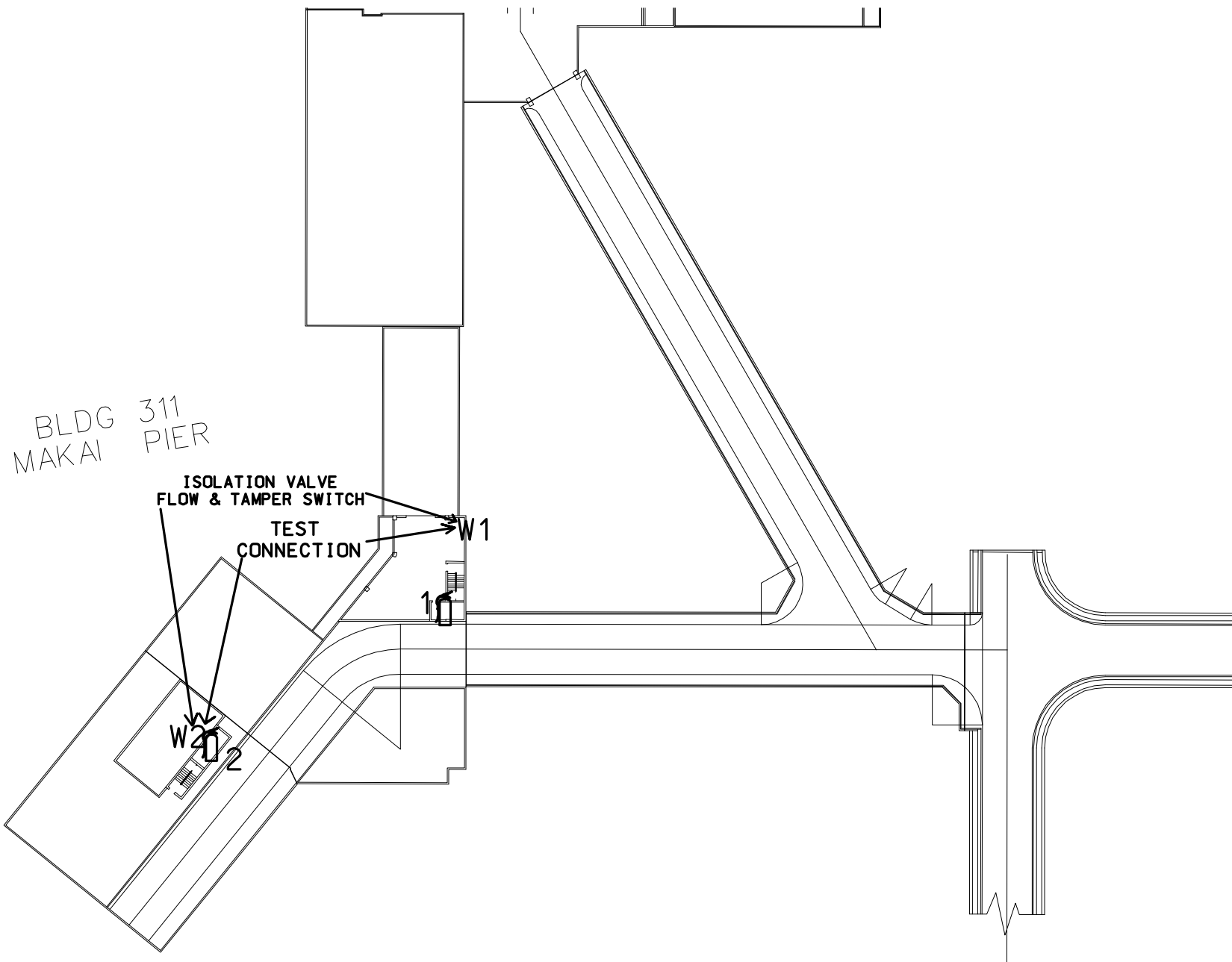

HONOLULU INTERNATIONAL AIRPORT  Airports Division		Date : FEBRUARY 2018	EXHIBIT:  SHT 5 OF 62
INTER-ISLAND TERMINAL - 3/F LOUNGE AREA, STORAGE & OFFICE SPACES		BO1542-43 Inspection and Maintenance of Airport Fire Protection Equipment	

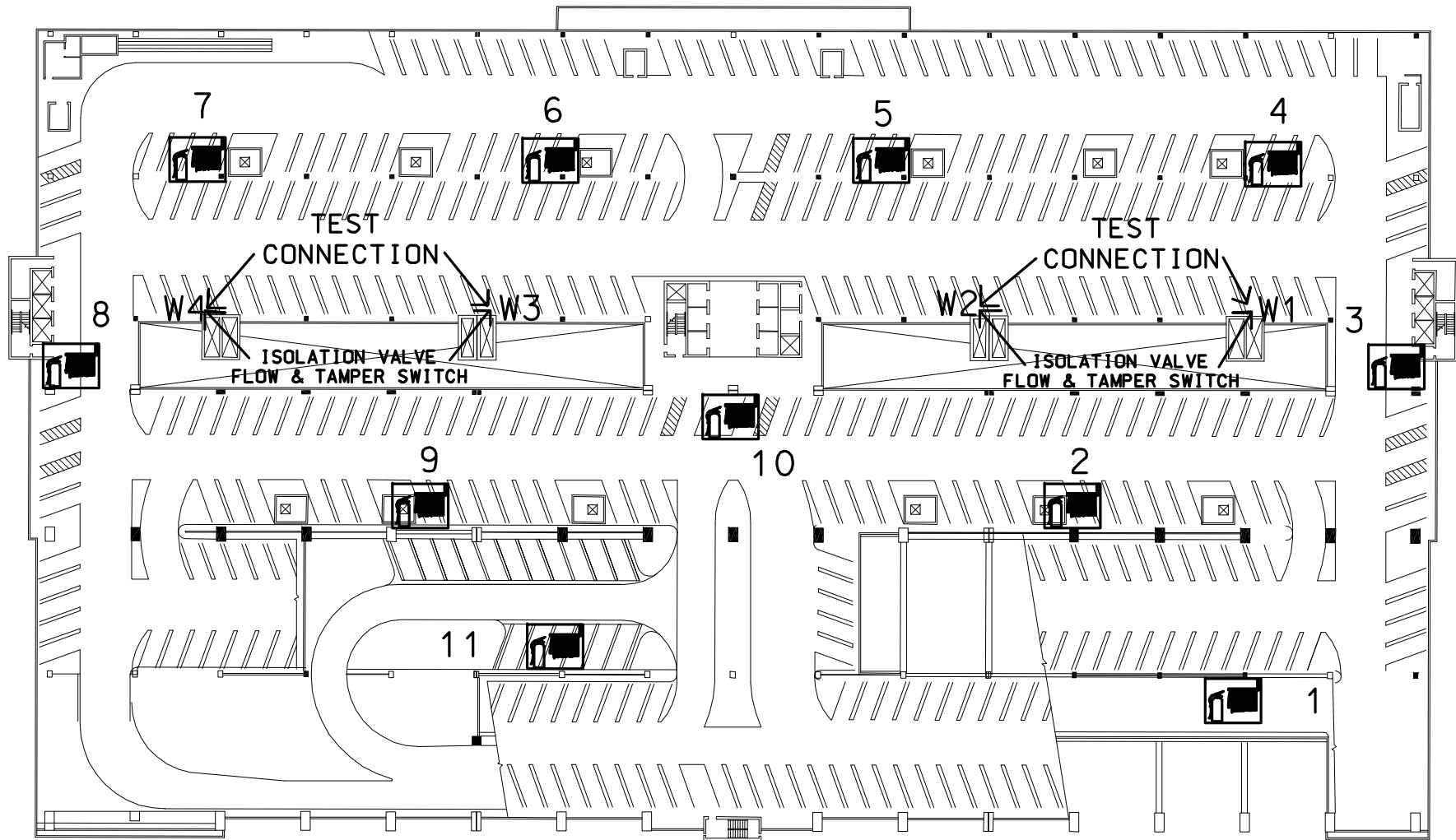

HONOLULU INTERNATIONAL AIRPORT  Airports Division		Date : FEBRUARY 2018	EXHIBIT: 
INTER-ISLAND TERMINAL MAKAI PIER 3/F ROOF TOP & ROADWAY LOCATIONS		BO1542-43 Inspection and Maintenance of Airport Fire Protection Equipment	SHT 6 OF 62

W:\AIRPORTS\HNL_HONOLULU\CAD\ENGINEERING\EM\BO1540-43\BO1540-43_SHT.6.DWG



HONOLULU INTERNATIONAL AIRPORT  Airports Division		Date : FEBRUARY 2018	EXHIBIT:  SHT 7 OF 62
INTER-ISLAND TERMINAL - 4/F PARKING STRUCTURE		BO1542-43 Inspection and Maintenance of Airport Fire Protection Equipment	

W:\AIRPORTS\HNL_HONOLULU\CAD\ENGINEERING\EA\BO1540-53\BO1540-53_SHT.7.DWG

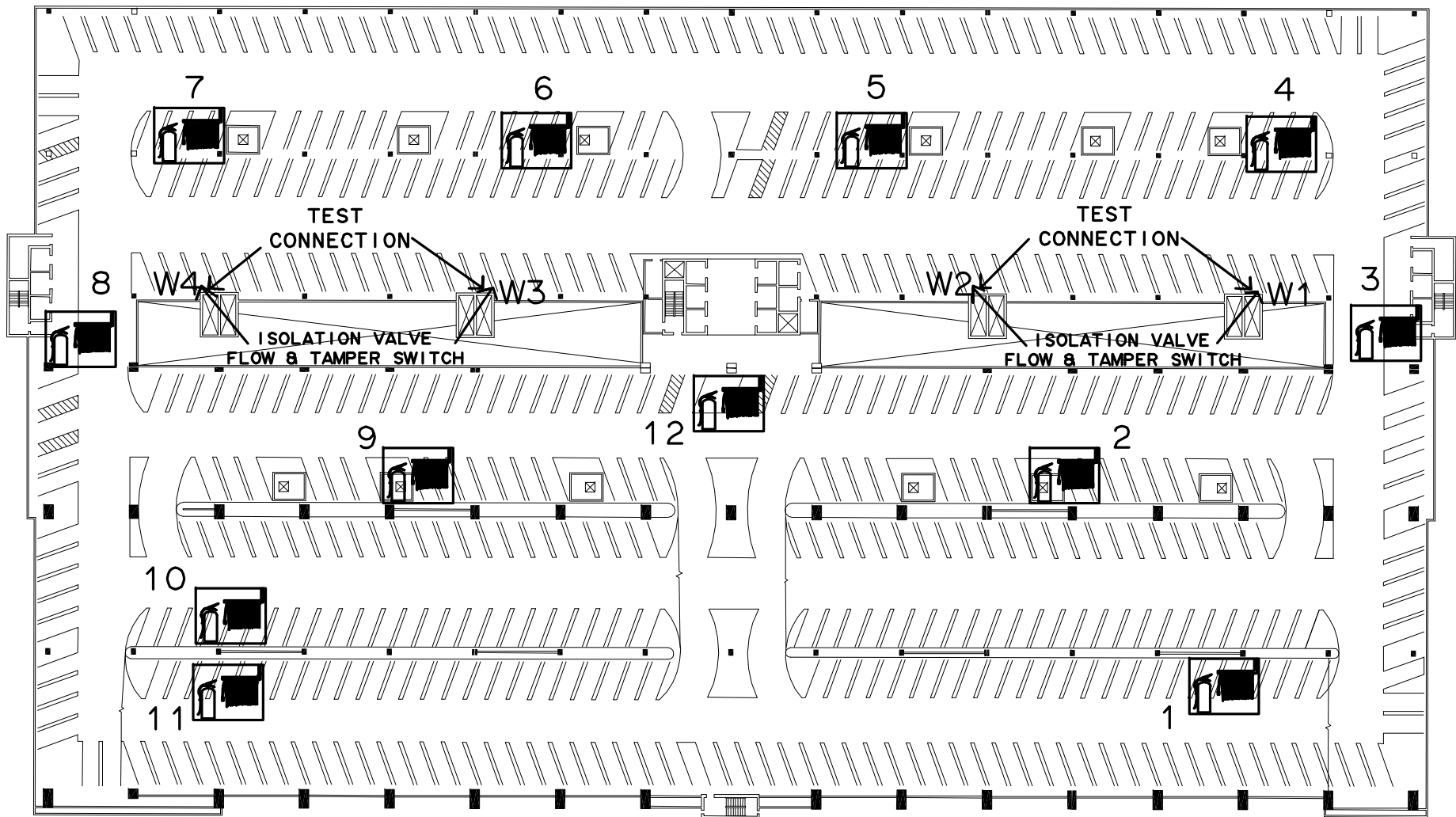

W:\AIRPORTS\HNL_HONOLULU\CAD\ENGINEERING\EA\BO1540-53\BO1540-53_SHT.8.rwg

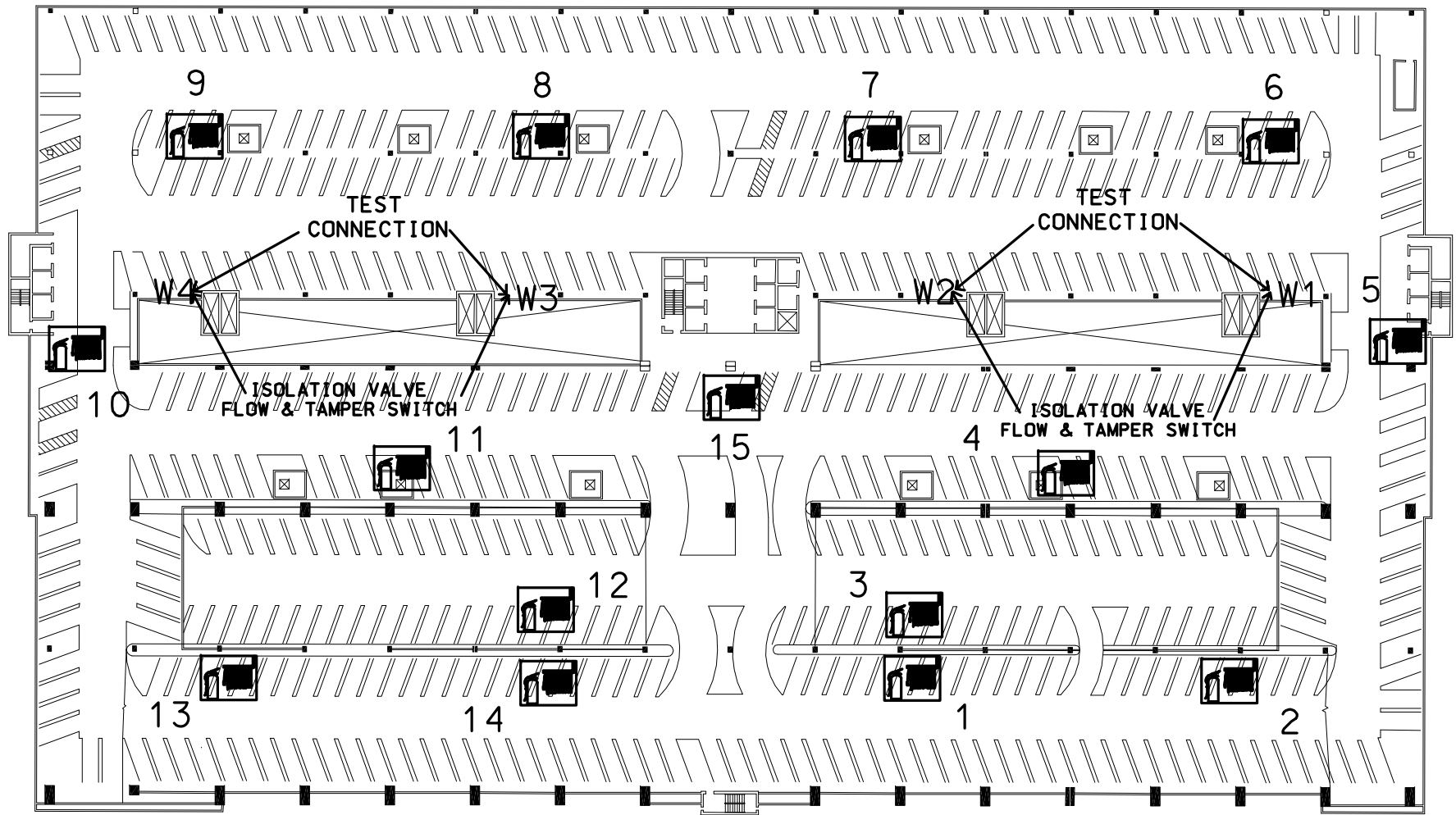

HONOLULU INTERNATIONAL AIRPORT

Date : FEBRUARY 2018

EXHIBIT:



INTER-ISLAND TERMINAL - 6/F
PARKING STRUCTURE

BO1542-43 Inspection and
Maintenance of Airport Fire
Protection Equipment



N:\AIRPORTS\HNL_HONOLULU\CAD\ENGINEERING\EA\BO1540-53\BO1540-53_SHT.9.DWG

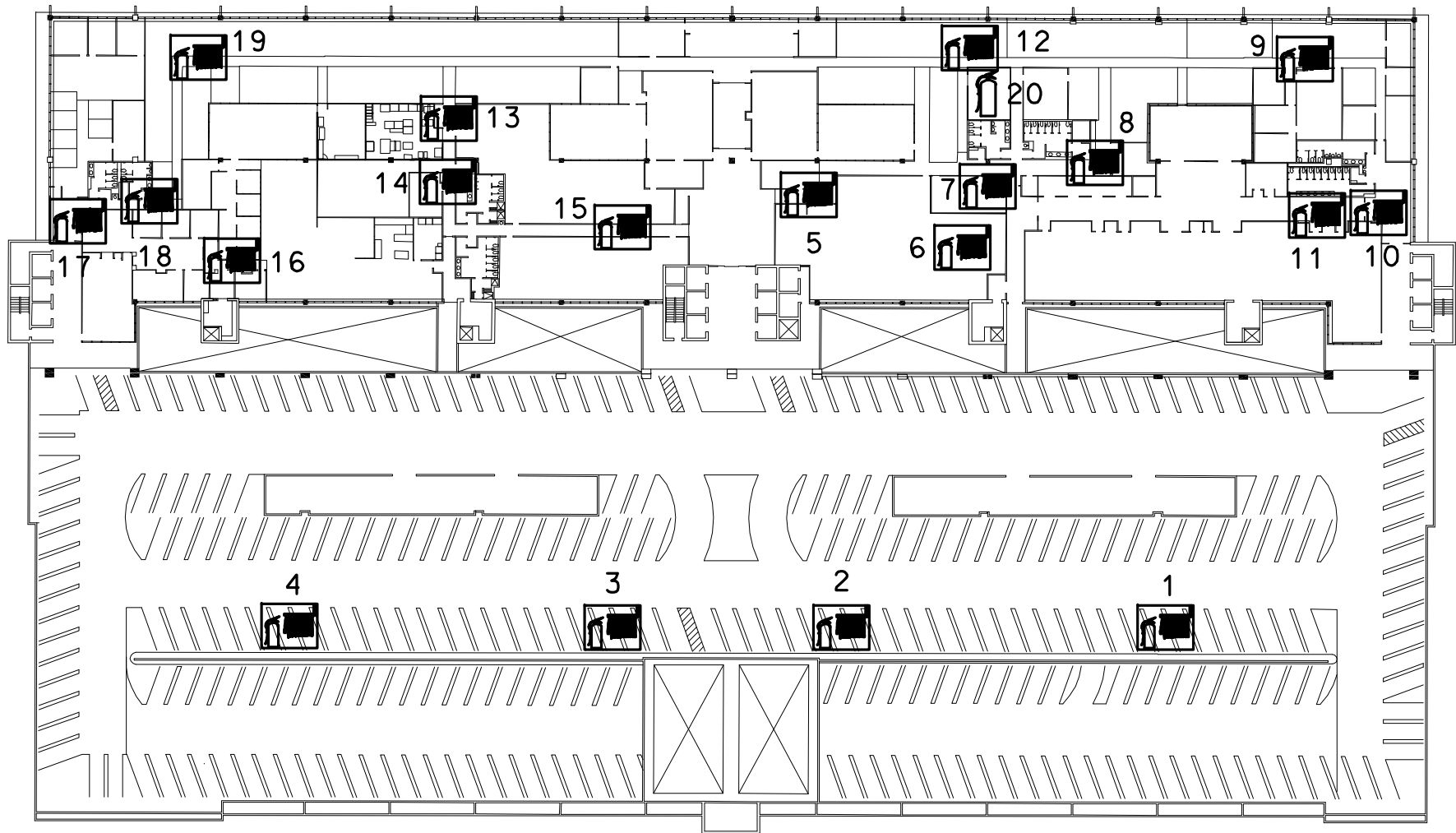

HONOLULU INTERNATIONAL AIRPORT

Date : FEBRUARY 2018

EXHIBIT:



**INTER-ISLAND TERMINAL - 7/F
OFFICE & PARKING STRUCTURE**

**BO1542-43 Inspection and
Maintenance of Airport Fire
Protection Equipment**



SHT 10 OF 62

N:\AIRPORTS\HNL_HONOLULU\CAD\ENGINEERING\EA\BO1540-53\BO1540-53_SHT_10.DWG

BLDG 310
INTER-ISLAND TERMINAL

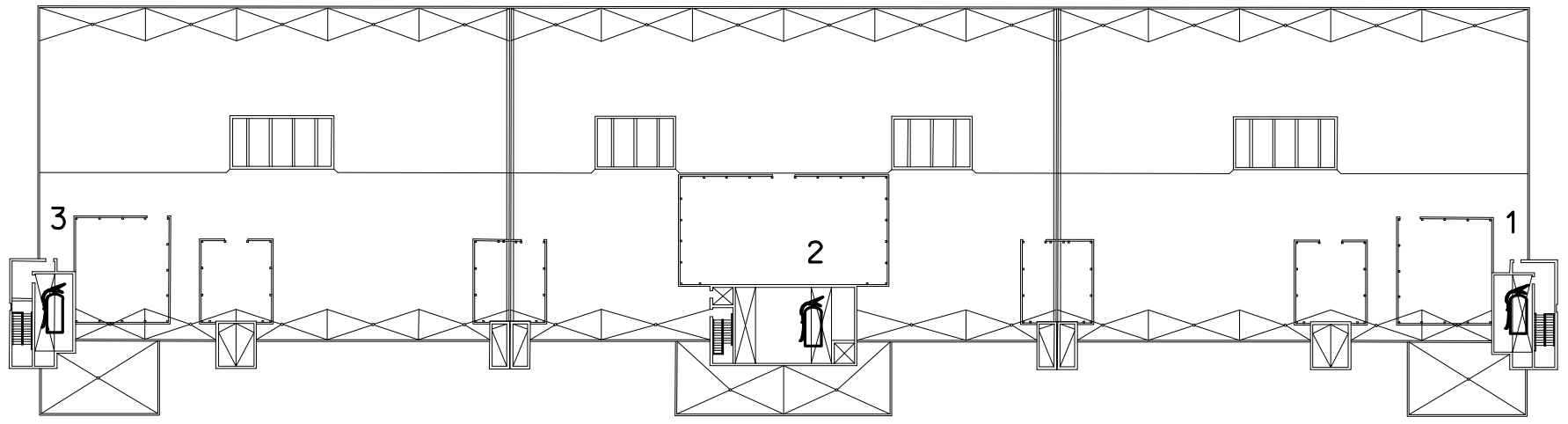

HONOLULU INTERNATIONAL AIRPORT		Date : FEBRUARY 2018	EXHIBIT:
 Airports Division	INTER-ISLAND TERMINAL BLDG. ROOF LEVEL	BO1542-43 Inspection and Maintenance of Airport Fire Protection Equipment	
			SHT 11 OF 62

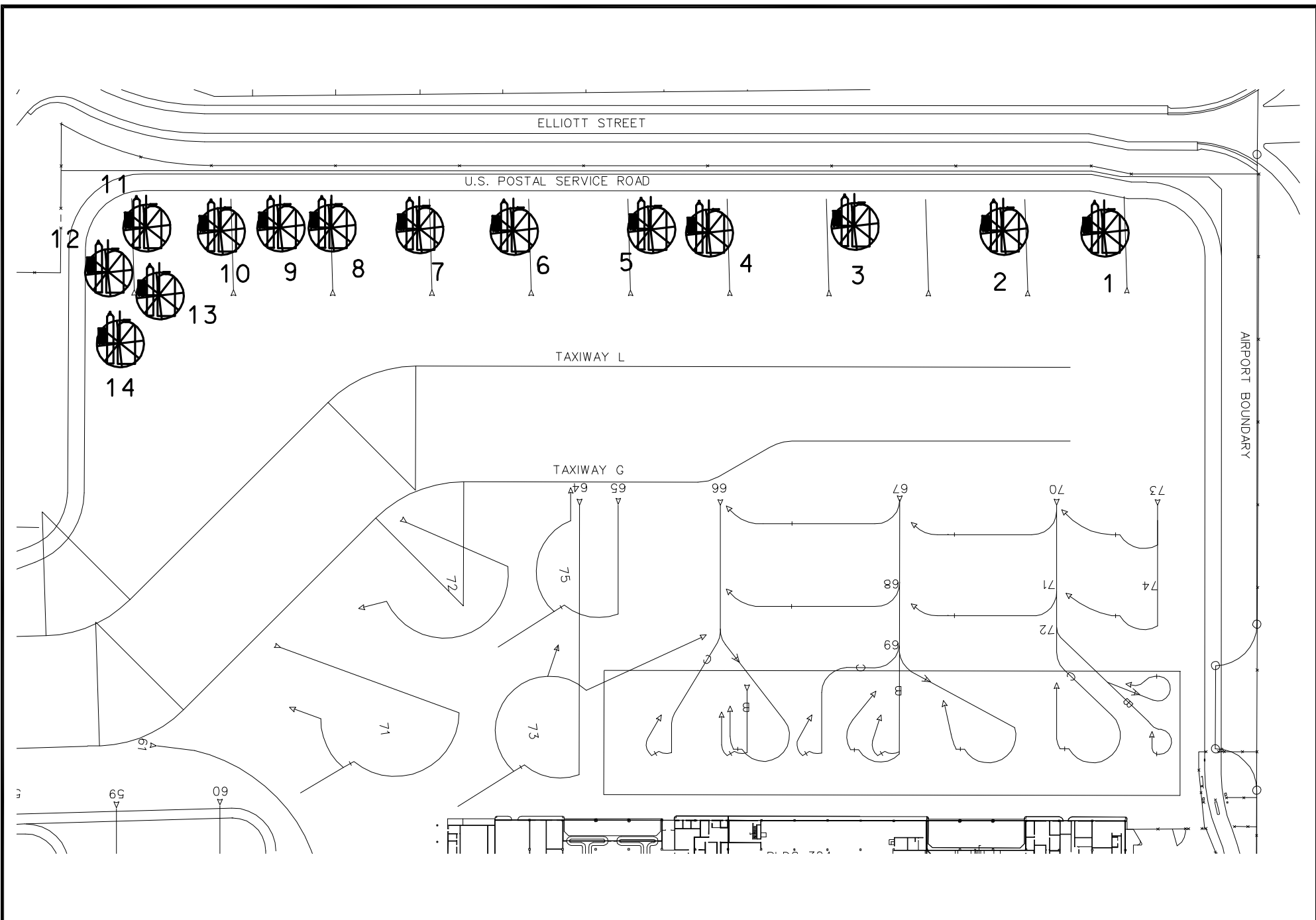

HONOLULU INTERNATIONAL AIRPORT  Airports Division		Date : FEBRUARY 2018	EXHIBIT: 
COMMUTER TERMINAL BUILDING G/F - HARDSTAND LOCATIONS		BO1542-43 Inspection and Maintenance of Airport Fire Protection Equipment	SHT 12 OF 62

W:\AIRPORTS\HNL\HONOLULU CAD\ENGINEERING\EA\BO1540-53\BO1540-53_SHT.12.DWG

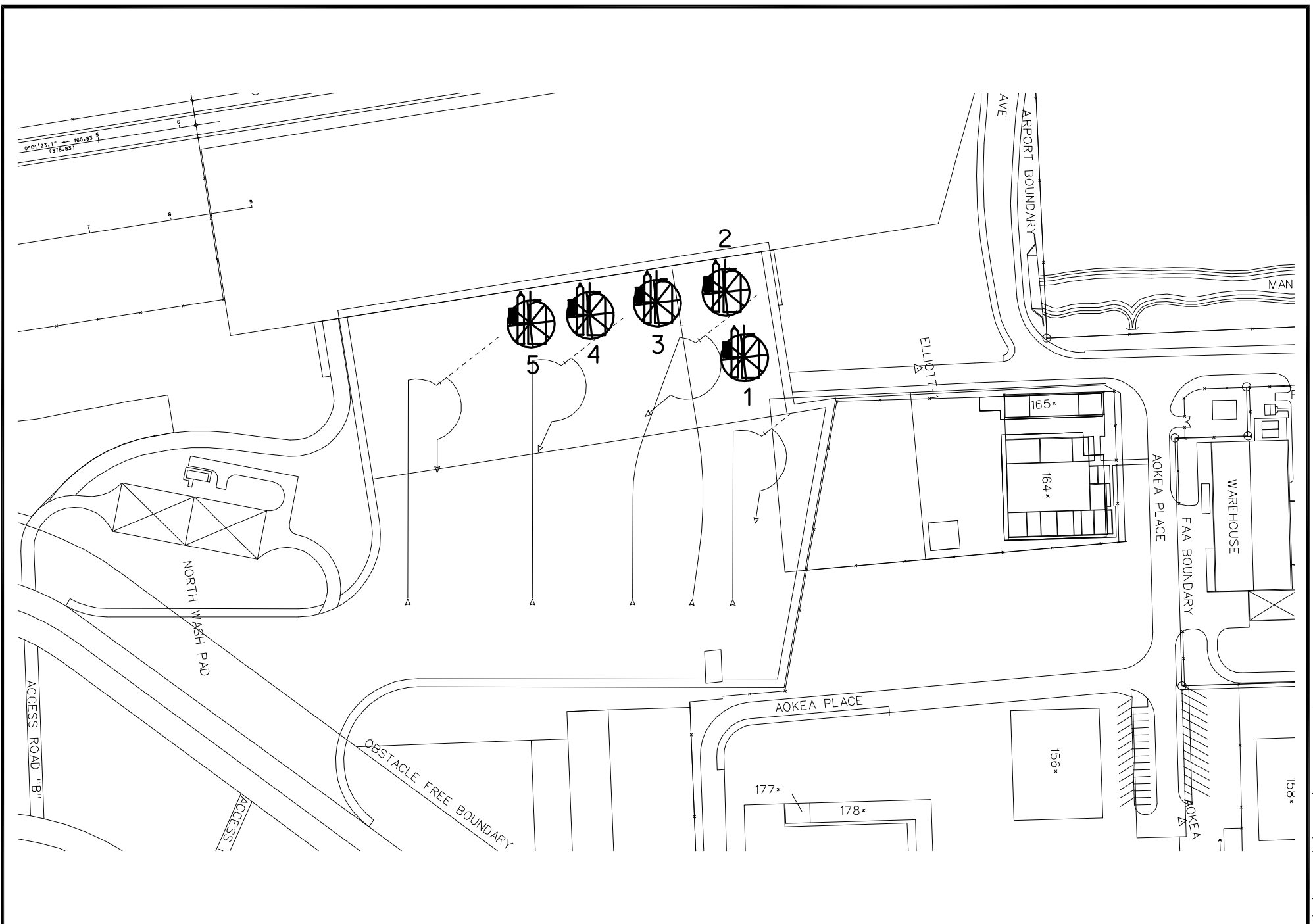

HONOLULU INTERNATIONAL AIRPORT  Airports Division		Date : FEBRUARY 2018	EXHIBIT: 
INTER-ISLAND TERMINAL - G/F FAR HARDSTAND LOCATIONS		BO1542-43 Inspection and Maintenance of Airport Fire Protection Equipment	A SHT 13 OF 62

H:\AIRPORTS\HNL\HONOLULU\CAD\ENGINEERING\EA\BO1540-43\BO1540-43_SHT.13.DWG

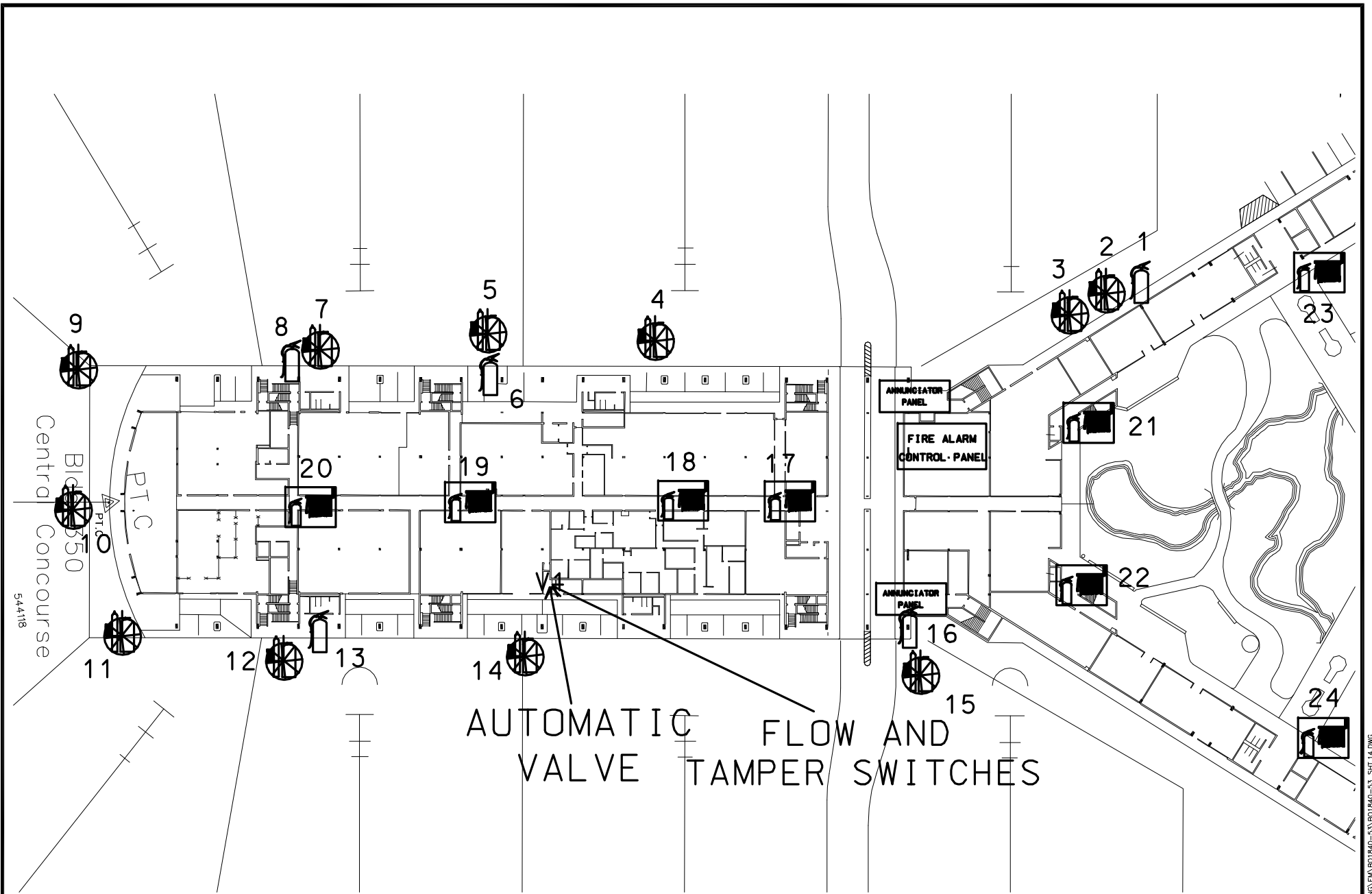

AUTOMATIC FLOW AND VALVE TAMPER SWITCHES

HONOLULU INTERNATIONAL AIRPORT  Airports Division		Date : FEBRUARY 2018 BO1542-43 Inspection and Maintenance of Airport Fire Protection Equipment	EXHIBIT:  SHT 14 OF 62
CENTRAL CONCOURSE - G/F HALLWAY, RAMP LOCATIONS & PORTIONS OF GARDEN			

W:\AIRPORTS\HNL\HONOLULU\CAD\ENGINEERING\EM\BO1540-53\BO1540-53_SHT_14.DWG

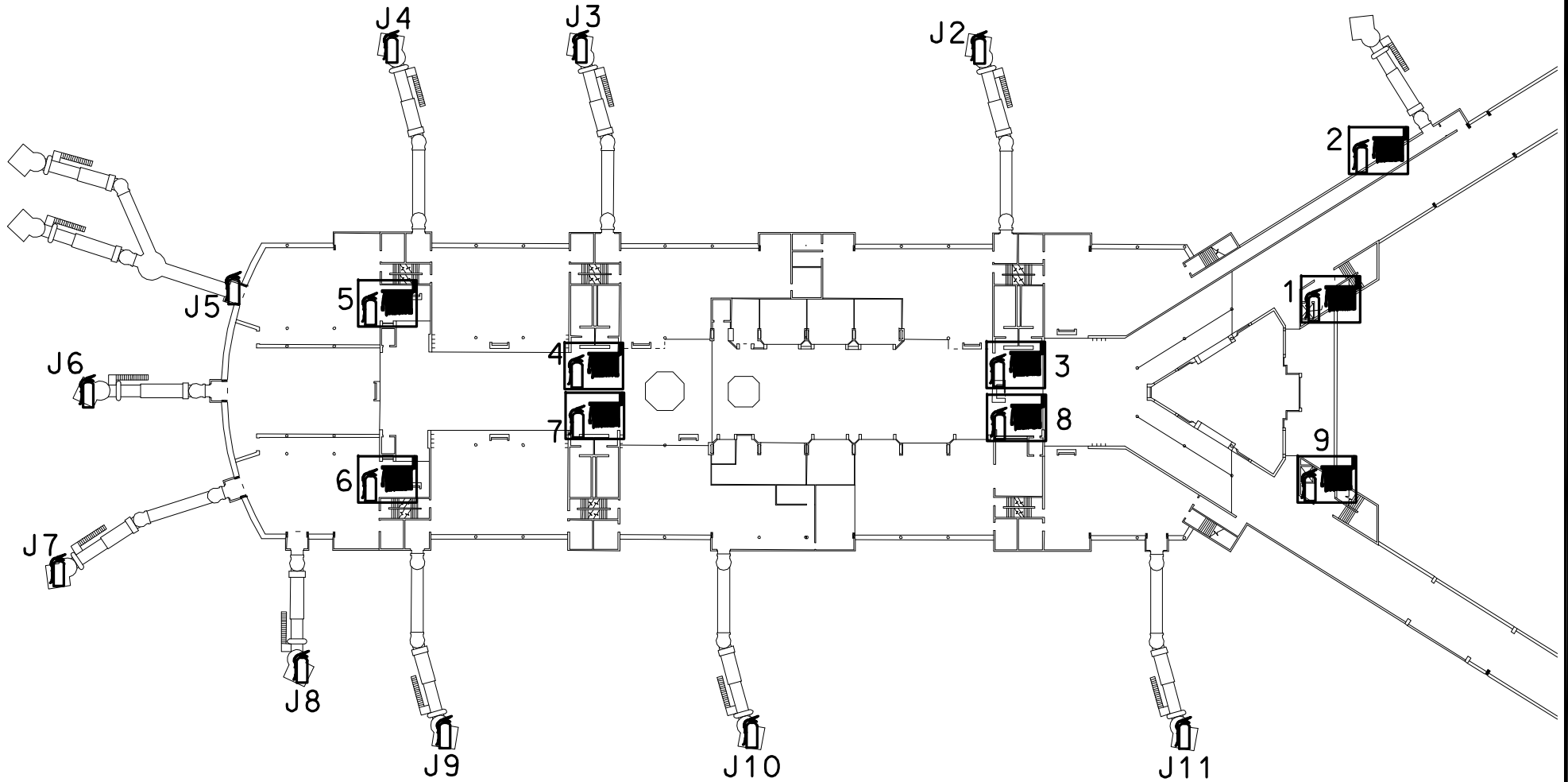

HONOLULU INTERNATIONAL AIRPORT

Date : FEBRUARY 2018



**CENTRAL CONCOURSE - 2/F
DEPARTING LOUNGE &
LOADING BRIDGE LOCATIONS**

**BO1542-43 Inspection and
Maintenance of Airport Fire
Protection Equipment**



EXHIBIT:

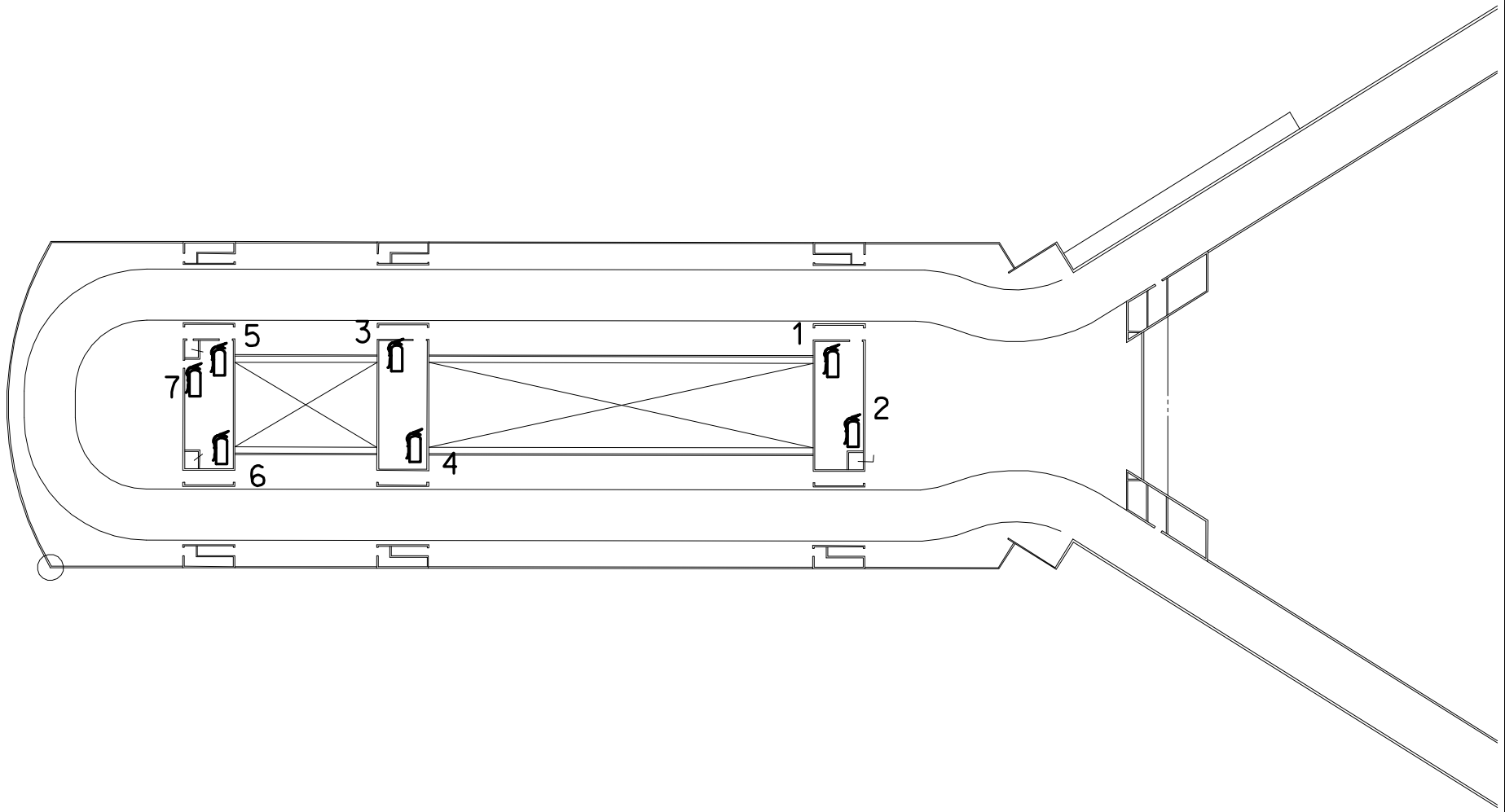

SHT 15 OF 62

N:\AIRPORTS\HNL\HONOLULU\CAD\ENGINEERING\EM\BO1540-43\BO1540-43_SHT_15.DWG



HONOLULU INTERNATIONAL AIRPORT  Airports Division		Date : FEBRUARY 2018	EXHIBIT: 
CENTRAL CONCOURSE 3/F - ROOF AREA		BO1542-43 Inspection and Maintenance of Airport Fire Protection Equipment	SHT 16 OF 62

N:\AIRPORTS\HNL\HONOLULU\CAD\ENGINEERING\EM\BO1540-53\BO1540-53_SHT.16.DWG

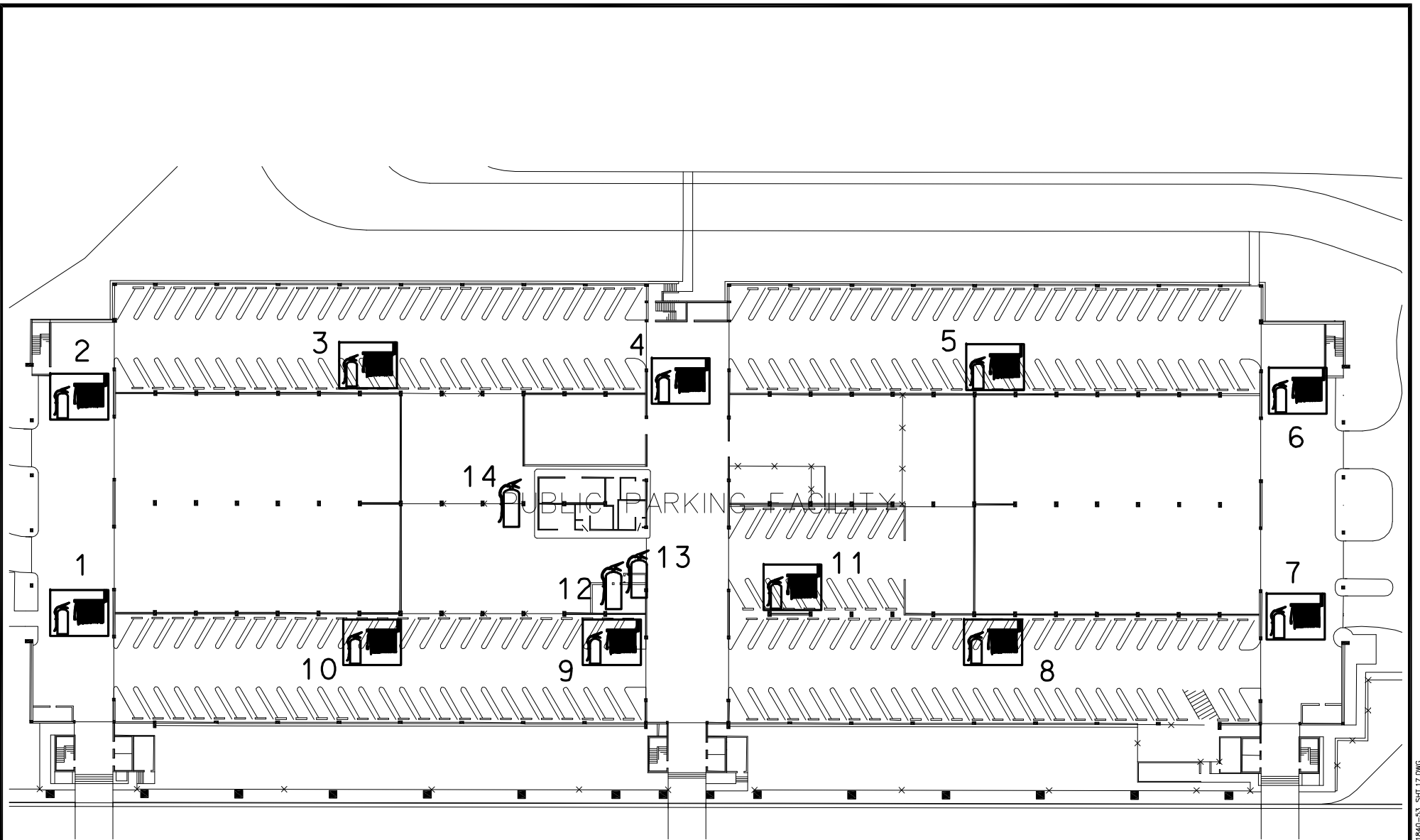

HONOLULU INTERNATIONAL AIRPORT  Airports Division		Date : FEBRUARY 2018	EXHIBIT: 
MAIN TERMINAL BUILDING G/F PARKING STRUCTURE		BO1542-43 Inspection and Maintenance of Airport Fire Protection Equipment	SHT 17 OF 62

W:\AIRPORTS\HNL_HONOLULU\CAD\ENGINEERING\EM\BO1540-43\BO1540-43_SHT.17.DWG

BUILDING 355
PUBLIC PARKING FACILITY
SECOND LEVEL

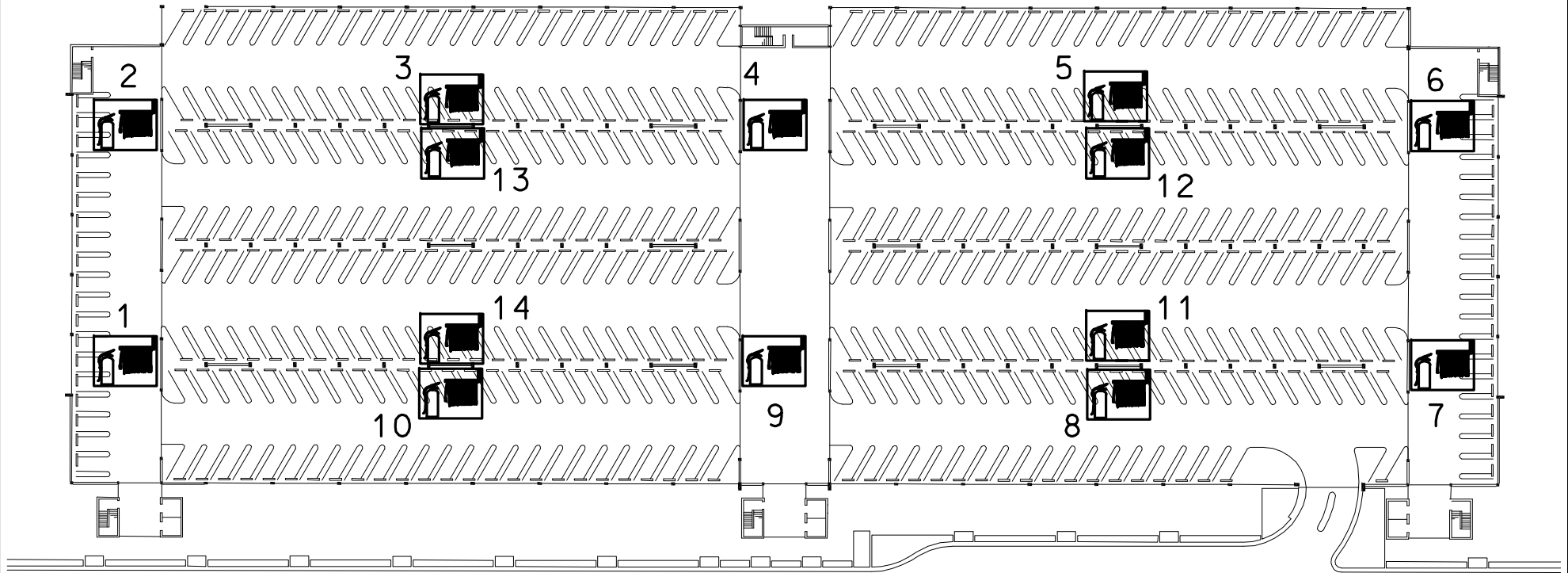

HONOLULU INTERNATIONAL AIRPORT

Date : FEBRUARY 2018

EXHIBIT:



MAIN TERMINAL BUILDING
2/F PARKING STRUCTURE

BO1542-43 Inspection and
Maintenance of Airport Fire
Protection Equipment



SHT 18 OF 62

N:\AIRPORTS\HNL\HONOLULU\CAD\ENGINEERING\EA\BO1540-43\BO1540-43_SHT_18.DWG

BLDG 355
PARKING STRUCTURE

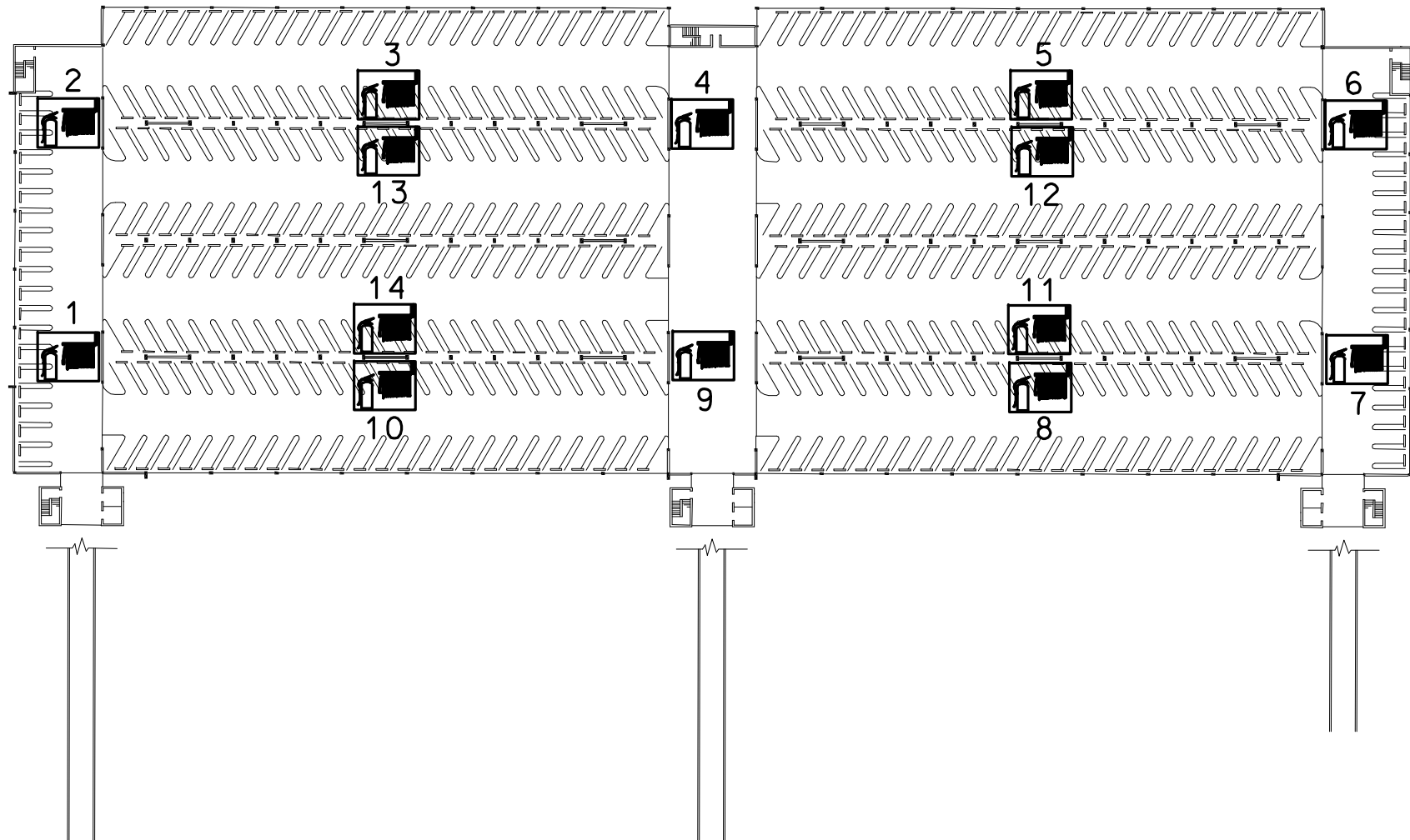

HONOLULU INTERNATIONAL AIRPORT  Airports Division		Date : FEBRUARY 2018	EXHIBIT: 
MAIN TERMINAL BUILDING 3/F PARKING STRUCTURE		BO1542-43 Inspection and Maintenance of Airport Fire Protection Equipment	SHT 19 OF 62

W:\AIRPORTS\HNL\HONOLULU\CAD\ENGINEERING\EM\BO1540-53\BO1540-53_SHT:19.DWG

BLDG 355
PARKING STRUCTURE

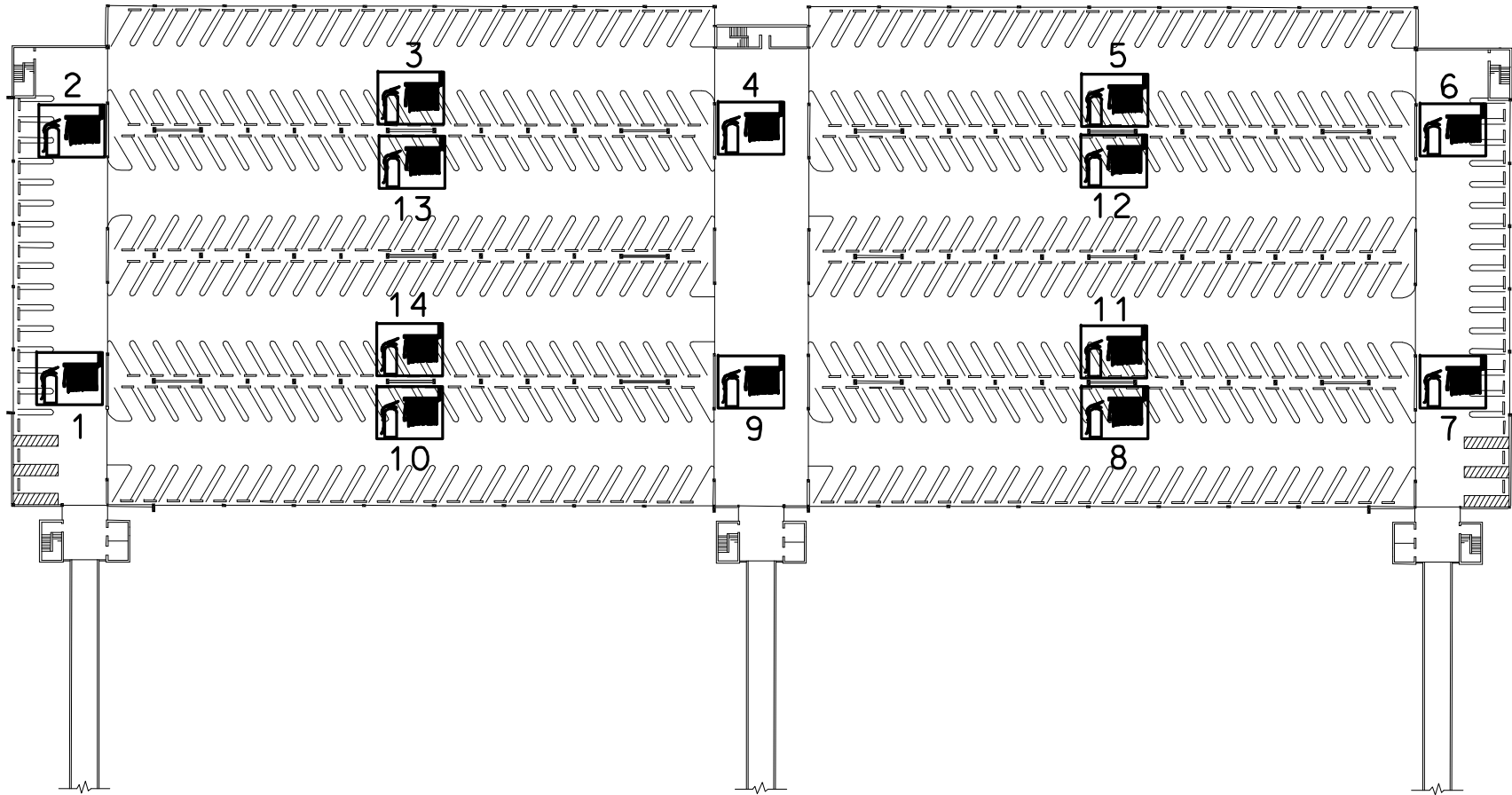

HONOLULU INTERNATIONAL AIRPORT

Date : FEBRUARY 2018



Airports Division

MAIN TERMINAL BUILDING
4/F PARKING STRUCTURE

BO1542-43 Inspection and
Maintenance of Airport Fire
Protection Equipment



EXHIBIT:



SHT 20 OF 62

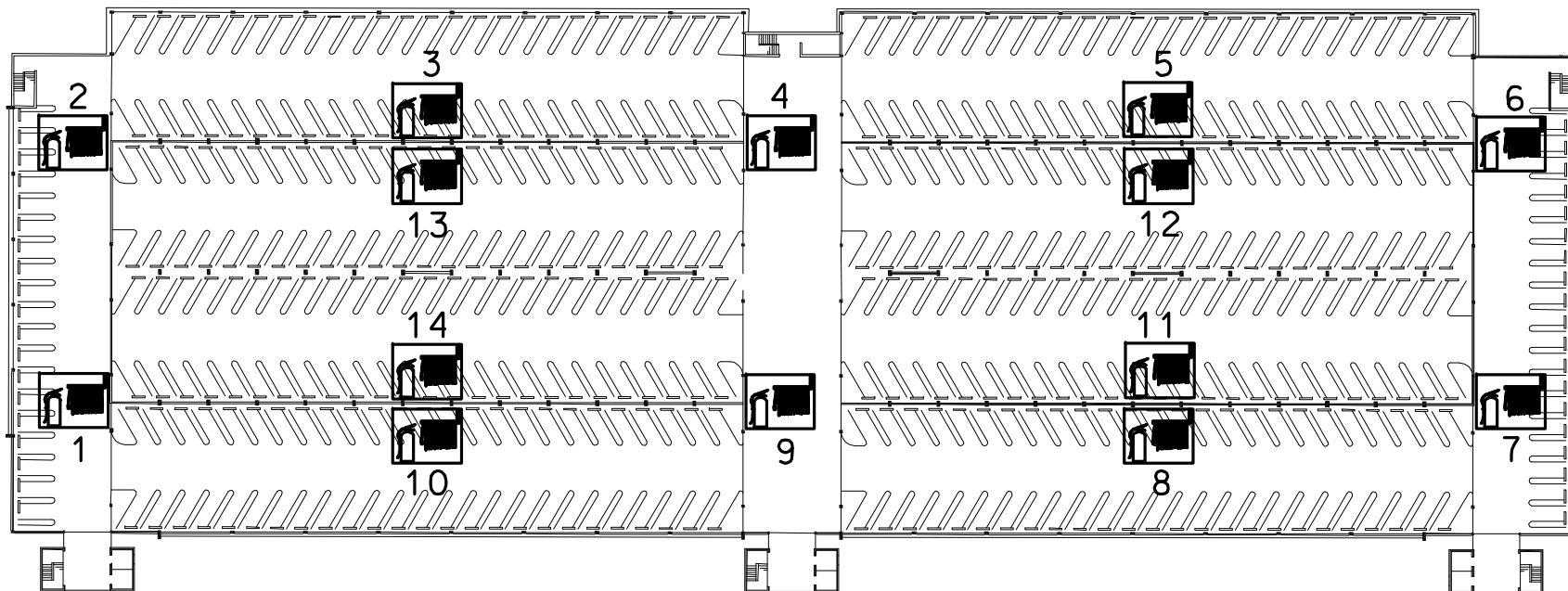

N:\AIRPORTS\HNL_HONOLULU\CAD\ENGINEERING\EM\BO1540-43\BO1540-43_SHT_20.DWG

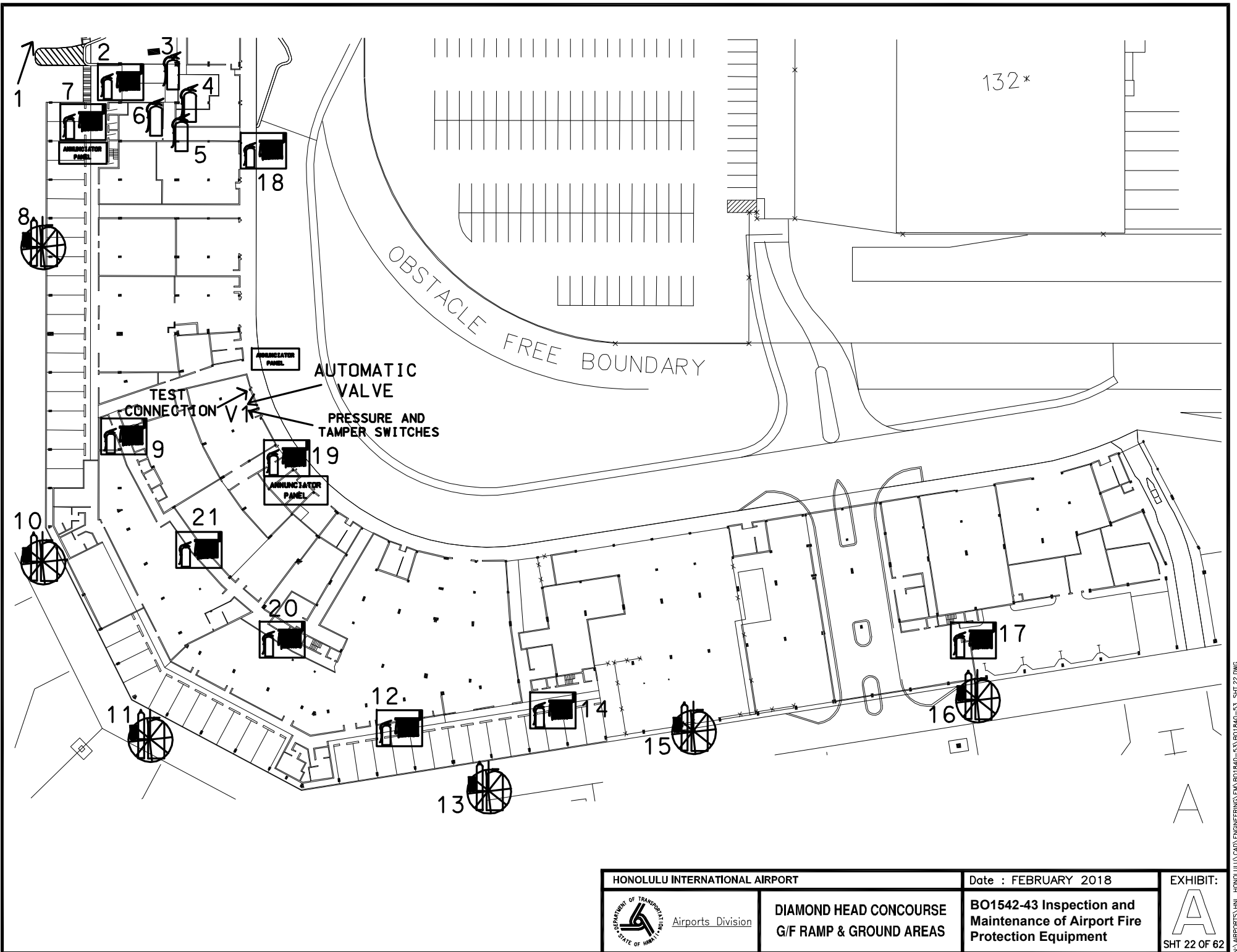

HONOLULU INTERNATIONAL AIRPORT  Airports Division		Date : FEBRUARY 2018	EXHIBIT: 
MAIN TERMINAL BUILDING 5/F PARKING STRUCTURE		BO1542-43 Inspection and Maintenance of Airport Fire Protection Equipment	SHT 21 OF 62

W:\AIRPORTS\HNL_HONOLULU\CAD\ENGINEERING\EM\BO1540-53\BO1540-53_SHT.21.DWG



HONOLULU INTERNATIONAL AIRPORT  Airports Division		Date : FEBRUARY 2018	EXHIBIT: 
DIAMOND HEAD CONCOURSE G/F RAMP & GROUND AREAS		BO1542-43 Inspection and Maintenance of Airport Fire Protection Equipment	SHT 22 OF 62

H:\AIRPORTS\HNL\HONOLULU CAD\ENGINEERING\EM\BO1540-53\BO1540-53_SHT_22.DWG

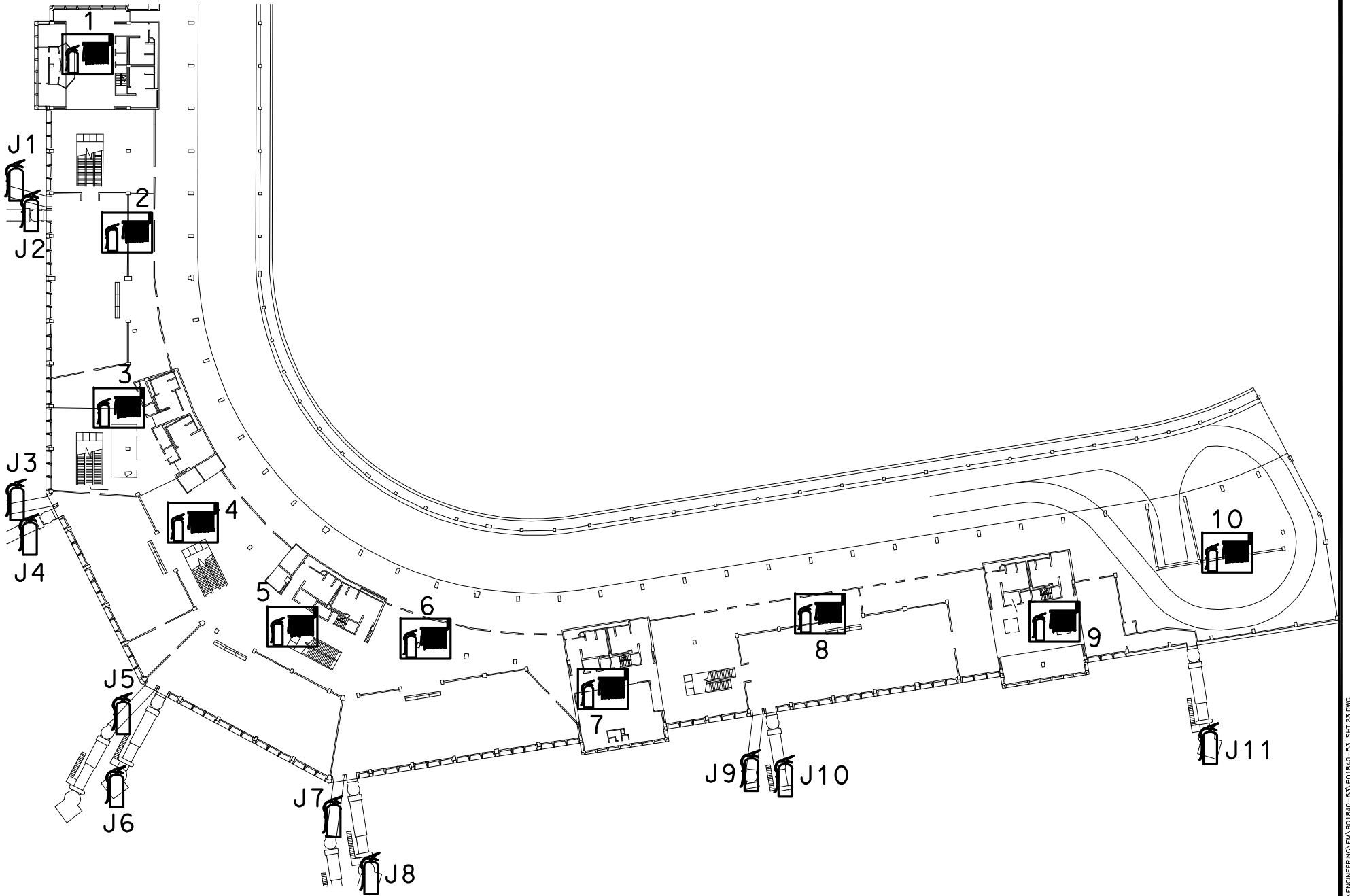

HONOLULU INTERNATIONAL AIRPORT

Date : FEBRUARY 2018

EXHIBIT:



**DIAMOND HEAD CONCOURSE
2/F GATE AREAS**

**BO1542-43 Inspection and
Maintenance of Airport Fire
Protection Equipment**



SHT 23 OF 62

BLDG 373
DIAMOND HEAD CONCOURSE

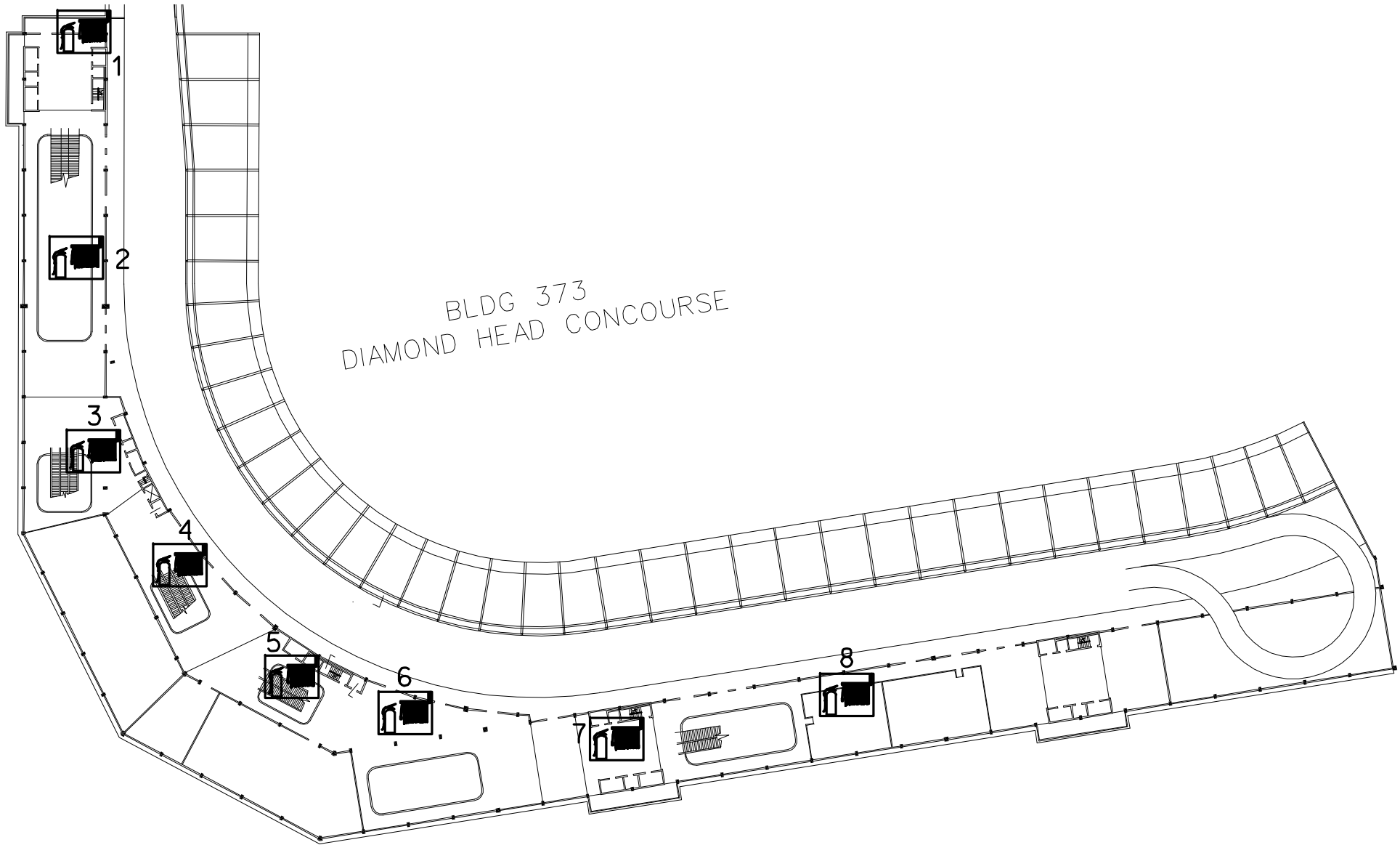

HONOLULU INTERNATIONAL AIRPORT

Date : FEBRUARY 2018

EXHIBIT:



Airports Division

DIAMOND HEAD CONCOURSE
3/F GATE AREAS

BO1542-43 Inspection and
Maintenance of Airport Fire
Protection Equipment





SHT 24 OF 62

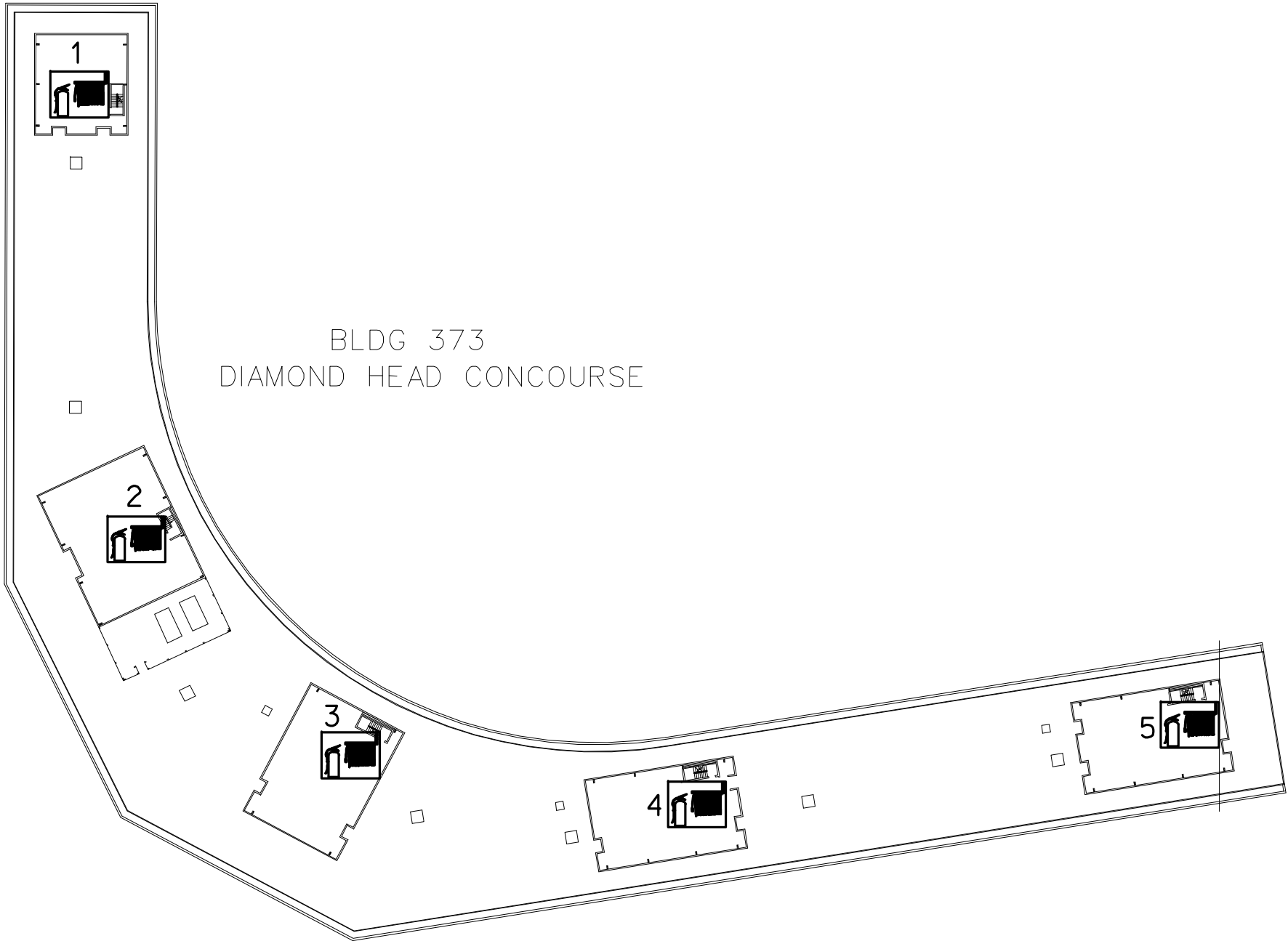

N:\AIRPORTS\HNL\HONOLULU\CAD\ENGINEERING\EA\BO1540-53\BO1540-53_SHT-24.DWG

BLDG 373
DIAMOND HEAD CONCOURSE

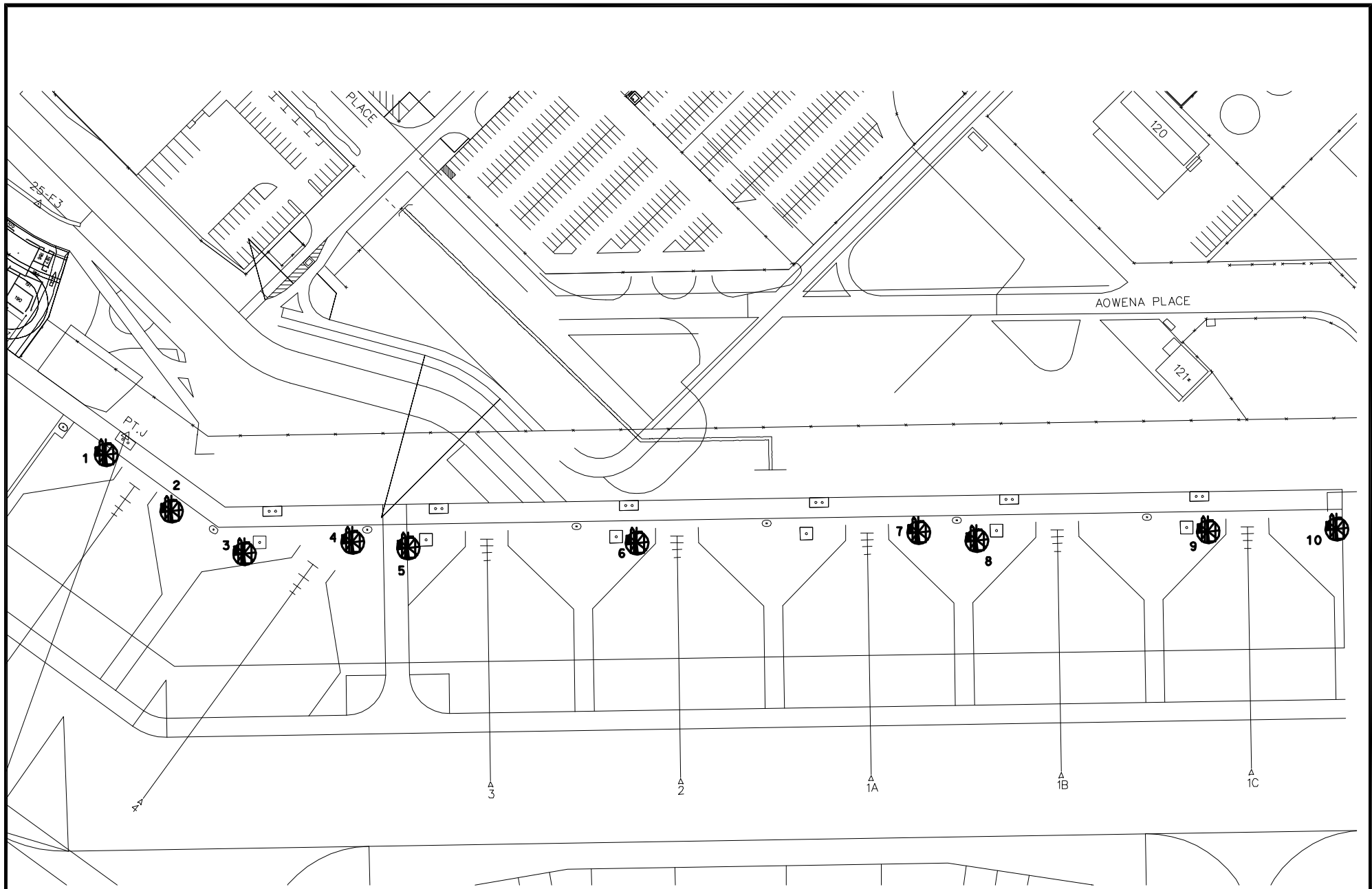

HONOLULU INTERNATIONAL AIRPORT		Date : FEBRUARY 2018	EXHIBIT:
 Airports Division	DIAMOND HEAD CONCOURSE	BO1542-43 Inspection and Maintenance of Airport Fire Protection Equipment	 SHT 25 OF 62
	4/F MECHANICAL ROOMS		



HONOLULU INTERNATIONAL AIRPORT  Airports Division		Date : FEBRUARY 2018	EXHIBIT:  SHT 26 OF 62
END OF DIAMOND HEAD CONCOURSE HARDSTAND G/F RAMP AREA		BO1542-43 Inspection and Maintenance of Airport Fire Protection Equipment	

W:\AIRPORTS\HNL\ENGINEERING\EA\BO1540-53\BO1540-53_SHT_26.DWG

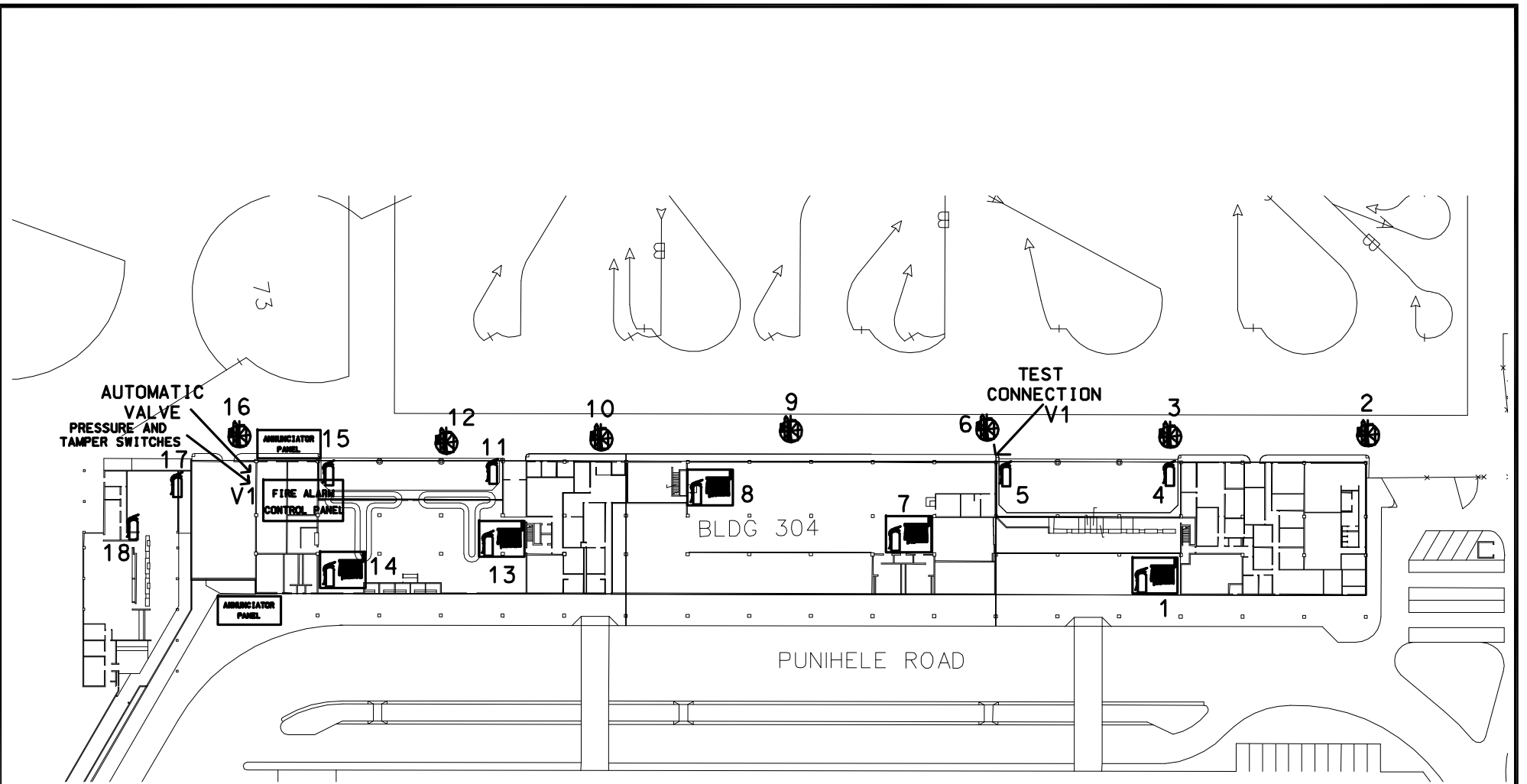

A

HONOLULU INTERNATIONAL AIRPORT  Airports Division		Date : FEBRUARY 2018	EXHIBIT: 
COMMUTER TERMINAL - G/F BAGGAGE CLAIM, TICKETING, GATES & RAMP LOCATIONS		BO1542-43 Inspection and Maintenance of Airport Fire Protection Equipment	SHT 27 OF 62

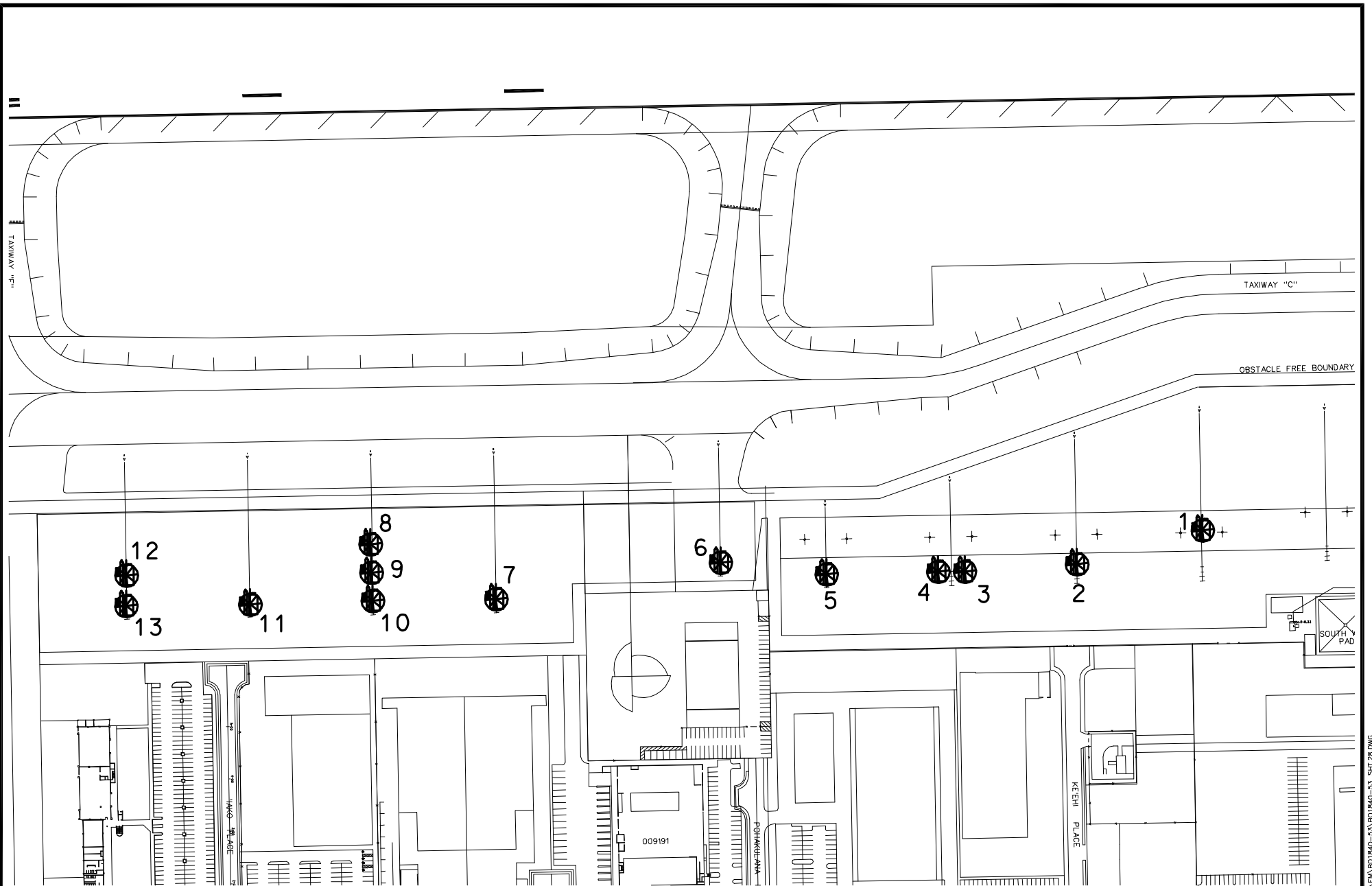

HONOLULU INTERNATIONAL AIRPORT

Date : FEBRUARY 2018

EXHIBIT:



**SOUTH RAMP HARDSTAND
APRON AND RAMP AREAS**

**BO1542-43 Inspection and
Maintenance of Airport Fire
Protection Equipment**



SHT 28 OF 62

I:\AIRPORTS\HNL\HONOLULU CAD\ENGINEERING\EM\BO1540-53\BO1540-53_SHT_28.DWG

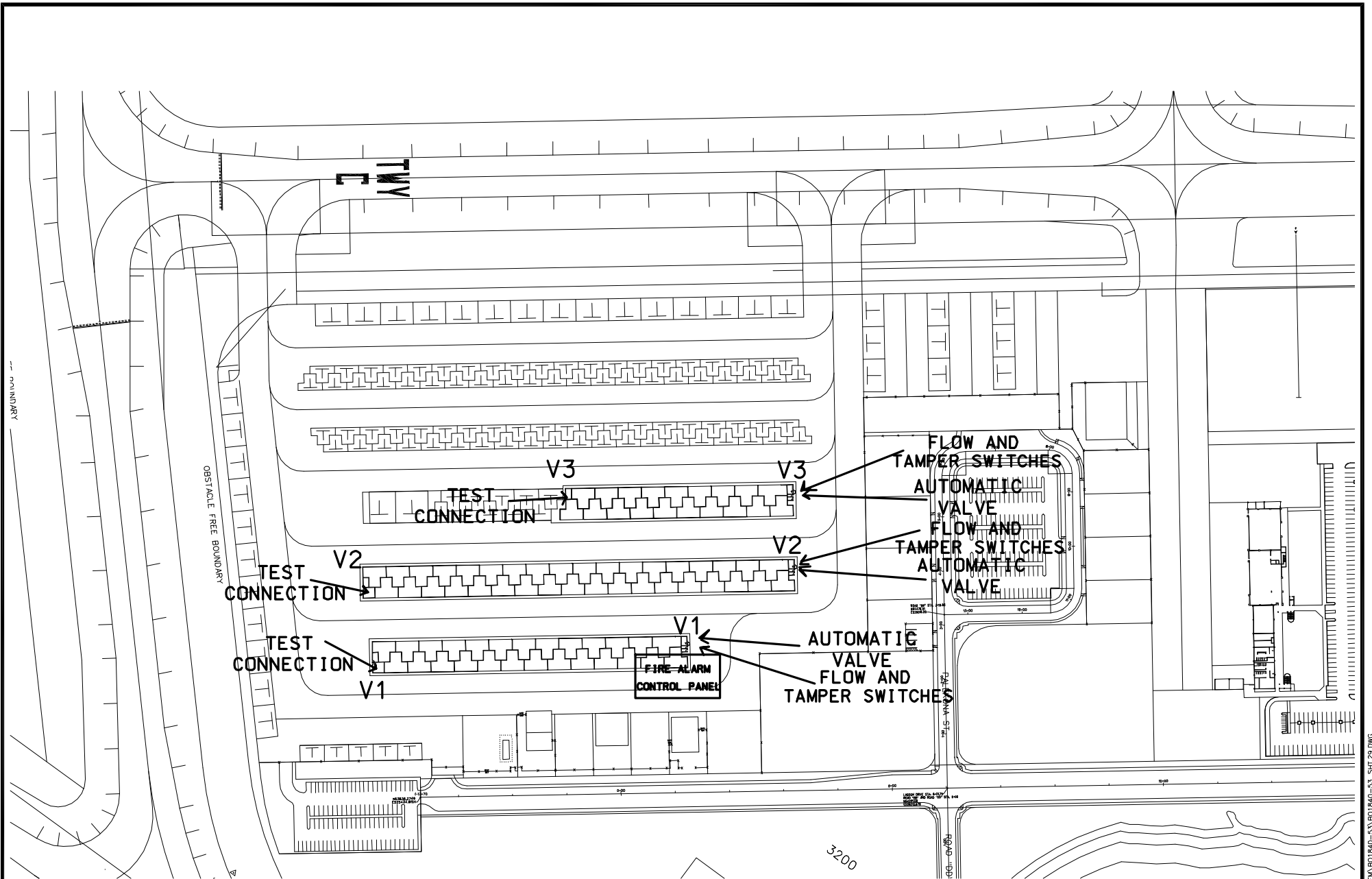

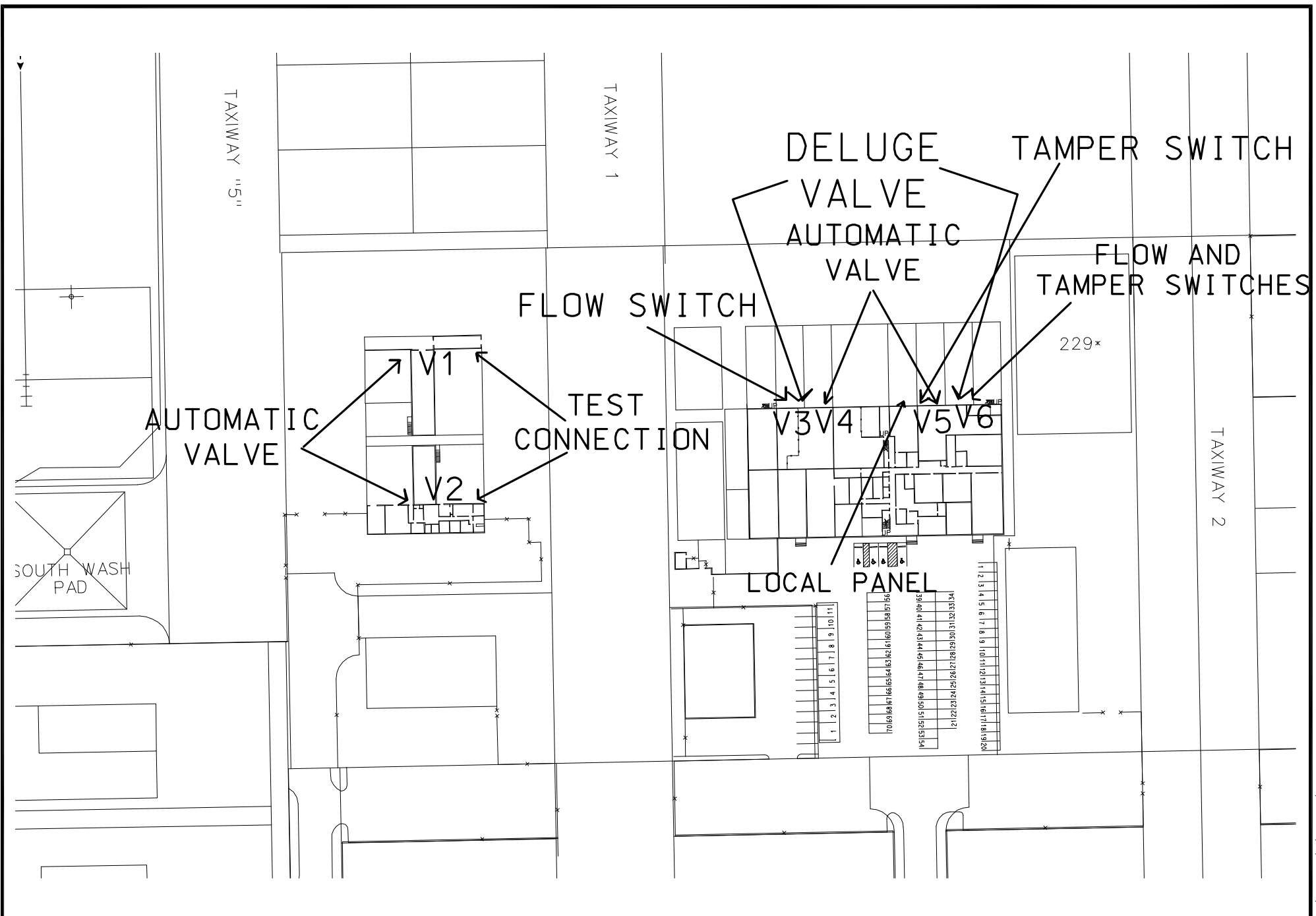

HONOLULU INTERNATIONAL AIRPORT  Airports Division		Date : FEBRUARY 2018	EXHIBIT: 
SOUTH RAMP T HANGARS APRONS AND RAMP AREAS		BO1542-43 Inspection and Maintenance of Airport Fire Protection Equipment	SHT 29 OF 62

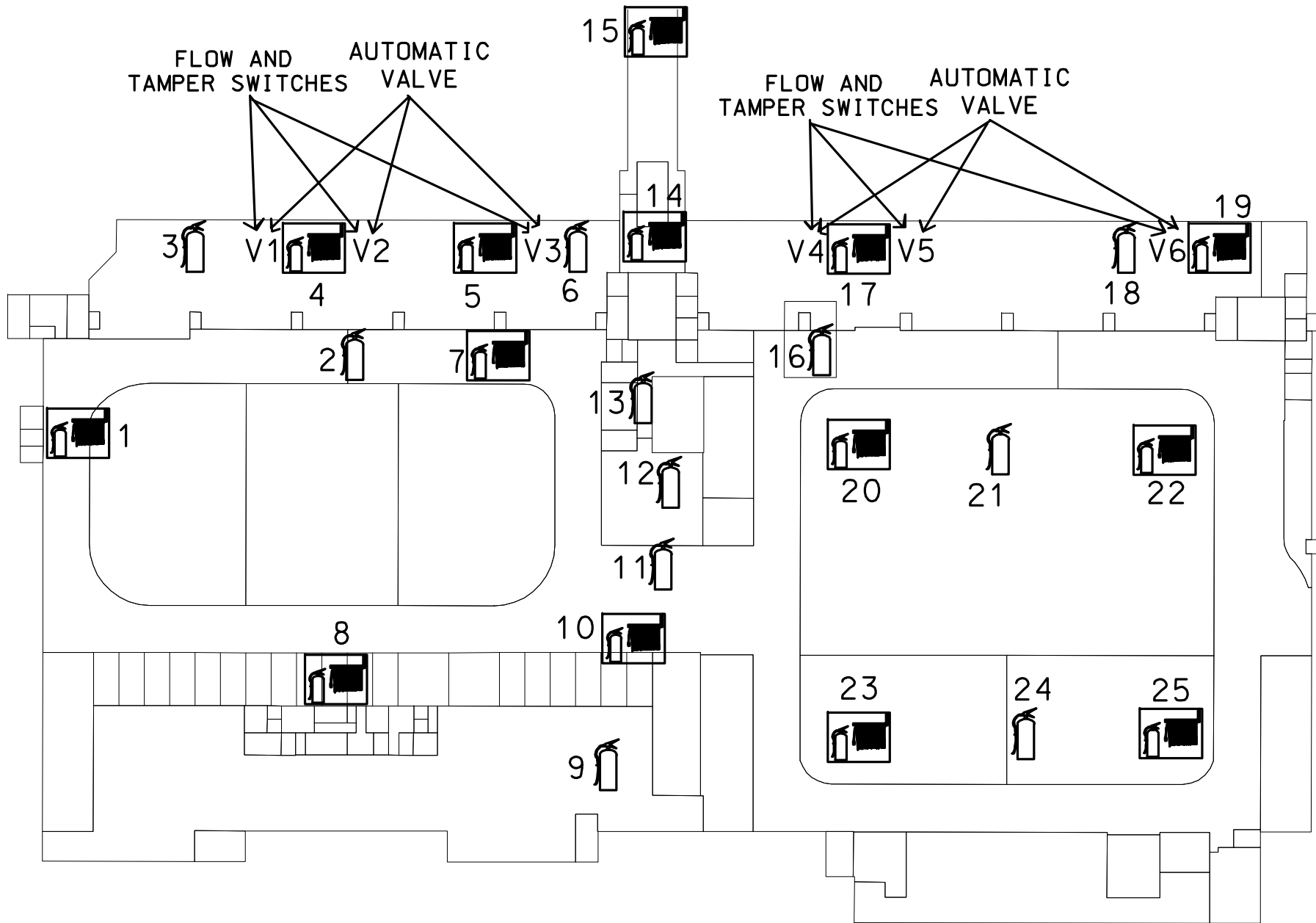

HONOLULU INTERNATIONAL AIRPORT  Airports Division		Date : FEBRUARY 2018	EXHIBIT:  SHT 30 OF 62
AIR SERVICE & HATS HANGARS SOUTH RAMP APRON & RAMP AREA		BO1542-43 Inspection and Maintenance of Airport Fire Protection Equipment	

W:\AIRPORTS\HNL\ENGINEERING\EA\BO1540-53\BO1540-53_SHT_30.DWG



HONOLULU INTERNATIONAL AIRPORT  Airports Division		Date : FEBRUARY 2018	EXHIBIT:  SHT 31 OF 62
EWA EXTENSION BASEMENT LEVEL		BO1542-43 Inspection and Maintenance of Airport Fire Protection Equipment	

W:\AIRPORTS\HNL_HONOLULU CAD\ENGINEERING\EA\BO1540-43\BO1540-43_SHT_31.DWG

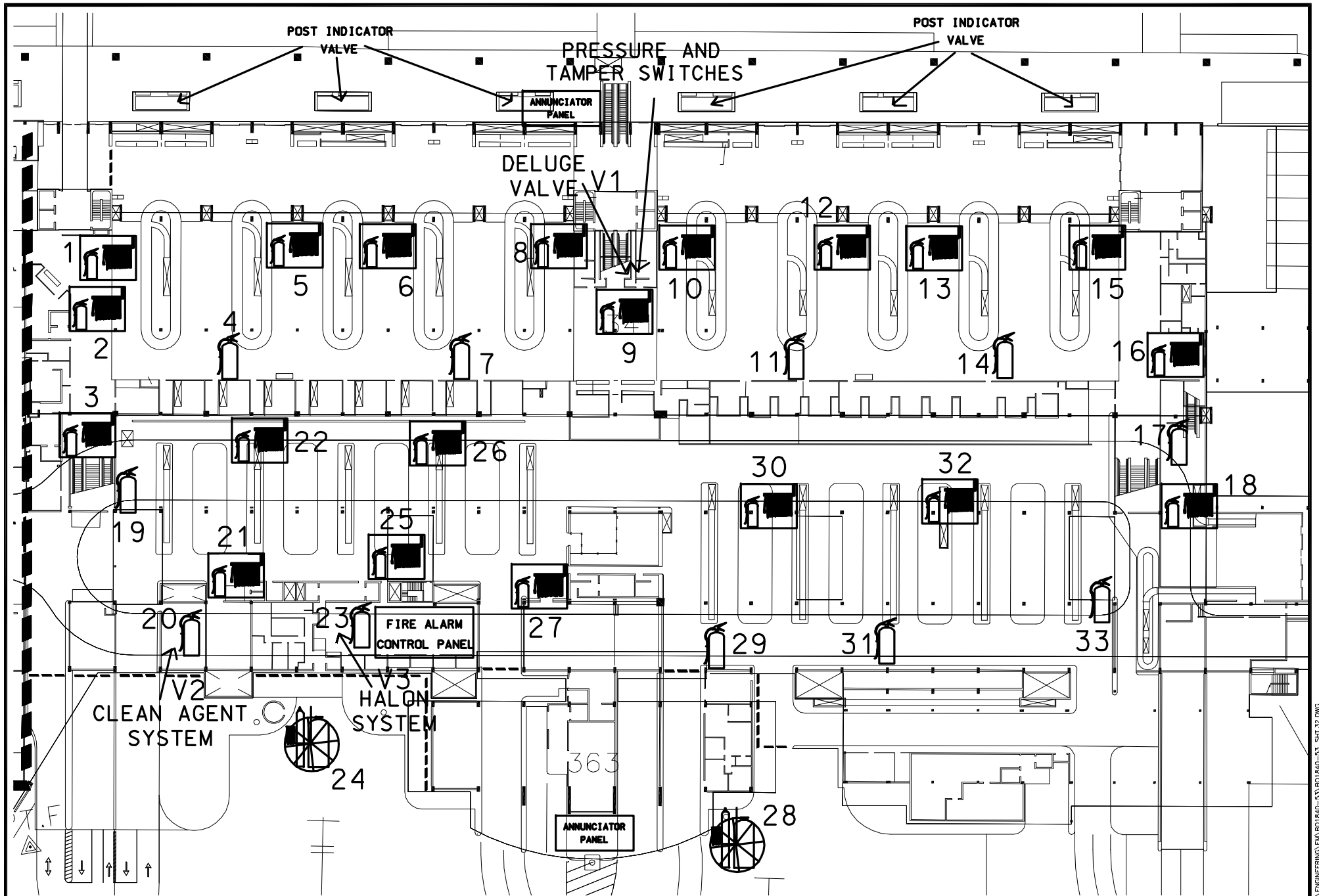

HONOLULU INTERNATIONAL AIRPORT  Airports Division		Date : FEBRUARY 2018	EXHIBIT: 
DIAMOND HEAD EXTENSION GROUND FLOOR		BO1542-43 Inspection and Maintenance of Airport Fire Protection Equipment	SHT 32 OF 62

H:\AIRPORTS\HNL_HONOLULU CAD (ENGINEERING)\EIA\BO1540-53\BO1540-53_SHT_32.DWG

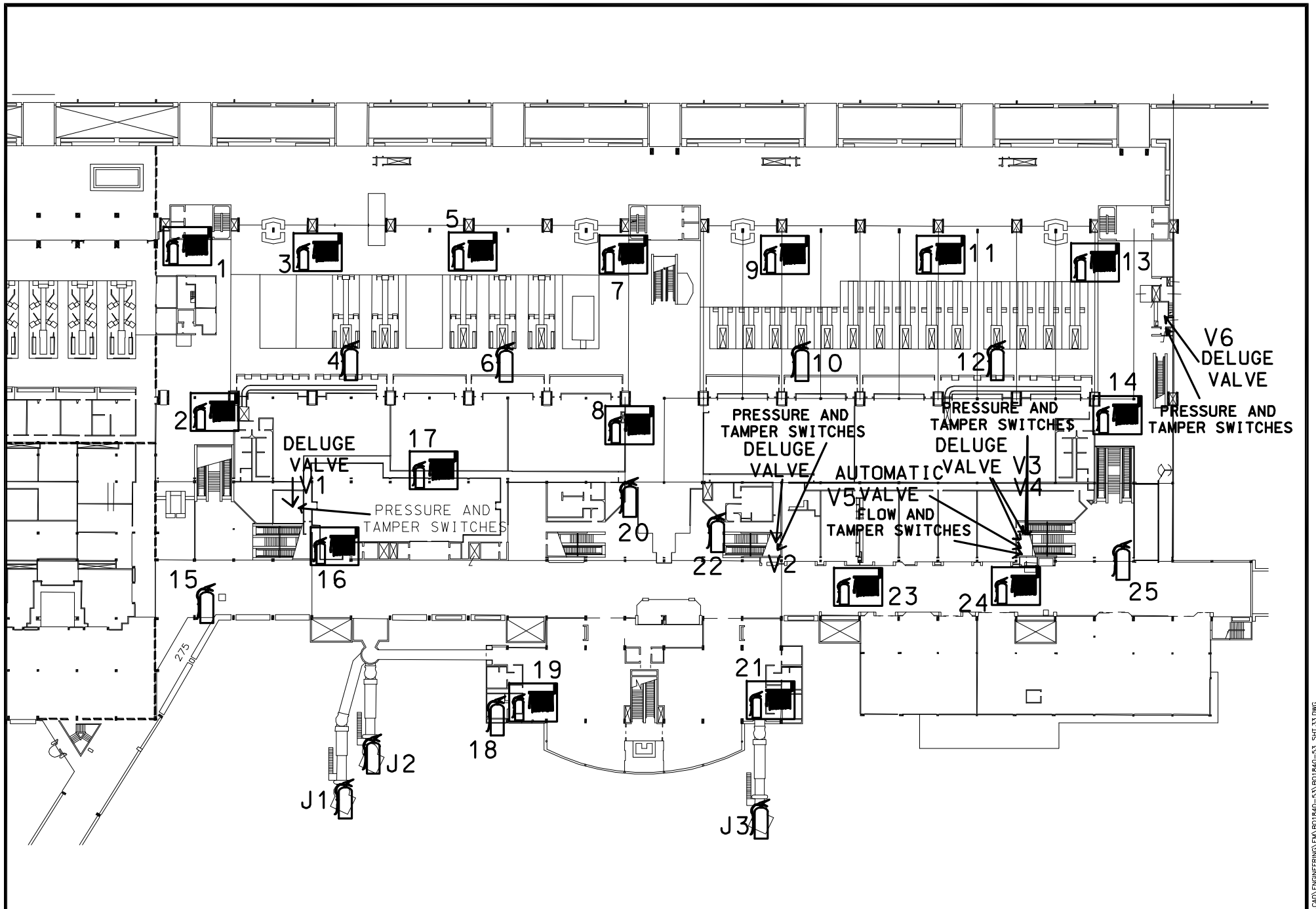

HONOLULU INTERNATIONAL AIRPORT  Airports Division		Date : FEBRUARY 2018	EXHIBIT: 
DIAMOND HEAD EXTENSION SECOND FLOOR		BO1542-43 Inspection and Maintenance of Airport Fire Protection Equipment	SHT 33 OF 62

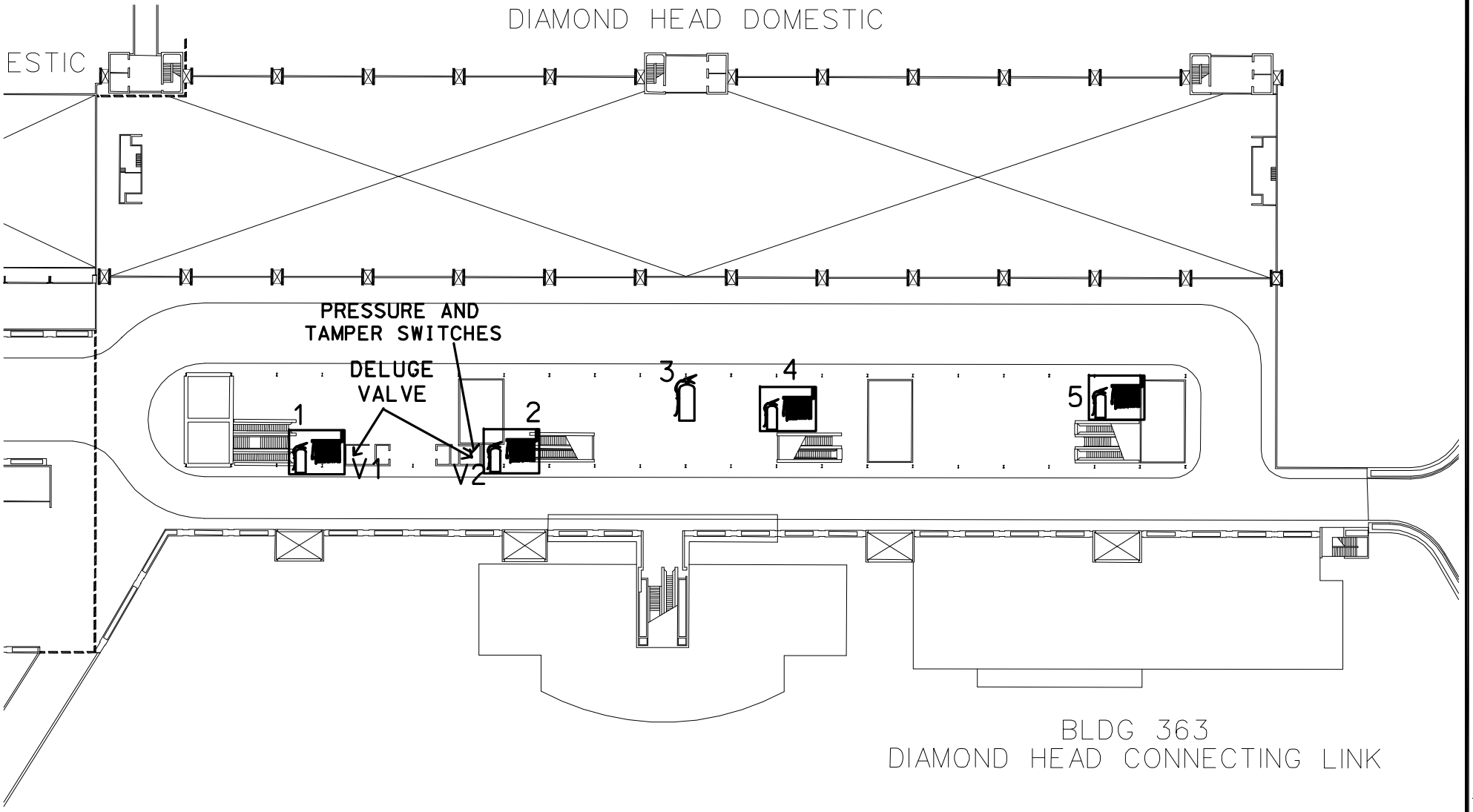

HONOLULU INTERNATIONAL AIRPORT  Airports Division		Date : FEBRUARY 2018	EXHIBIT: 
DIAMOND HEAD EXTENSION THIRD FLOOR		BO1542-43 Inspection and Maintenance of Airport Fire Protection Equipment	SHT 34 OF 62

W:\AIRPORTS\HNL\HONOLULU CAD\ENGINEERING\EM\BO1540-43\BO1540-43_SHT_34.DWG

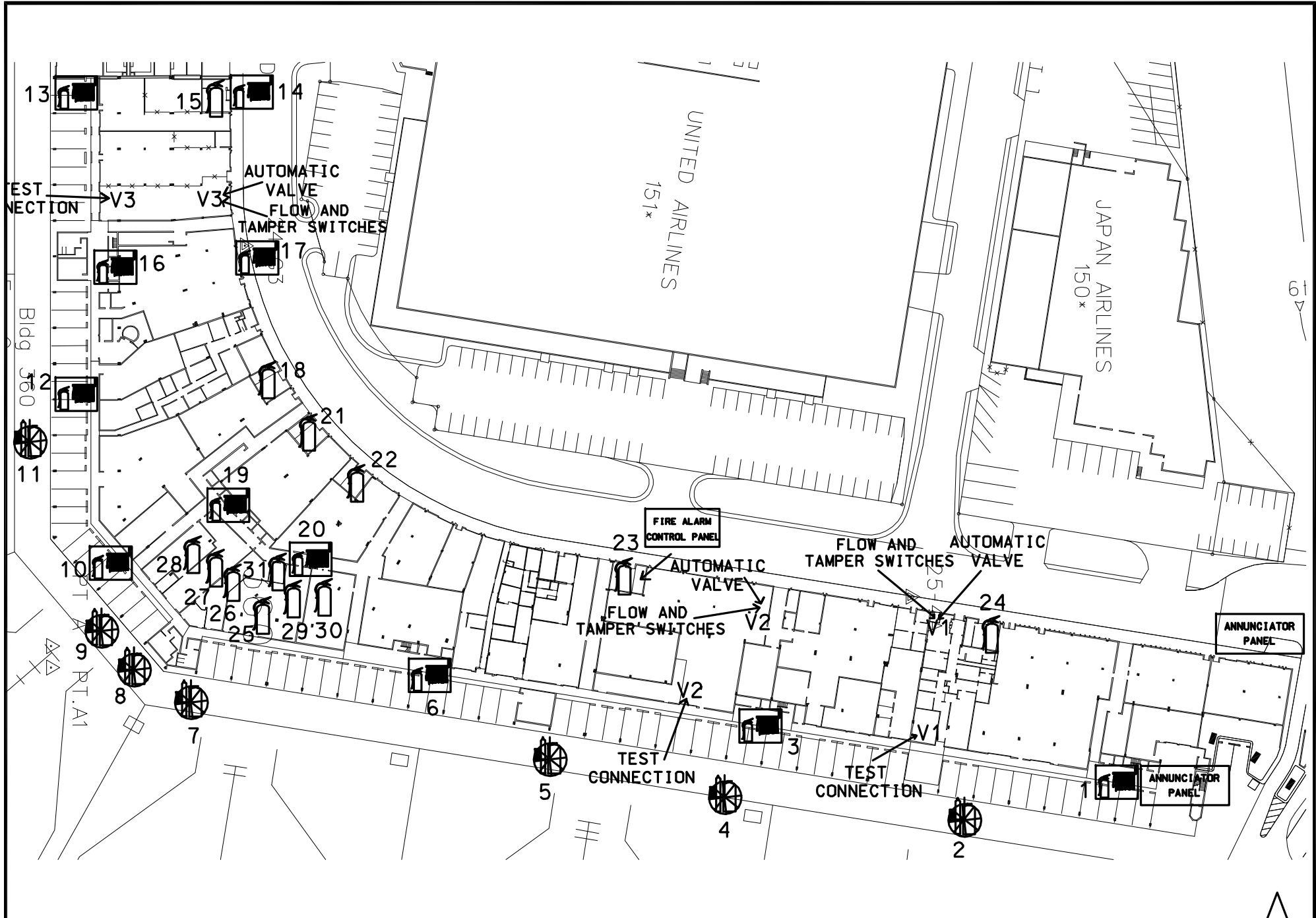

HONOLULU INTERNATIONAL AIRPORT  Airports Division		Date : FEBRUARY 2018	EXHIBIT: 
EWA CONCOURSE - G/F RAMP AREA AND OFFICES		BO1542-43 Inspection and Maintenance of Airport Fire Protection Equipment	SHT 35 OF 62

H:\AIRPORTS\HNL_HONOLULU\CAD\ENGINEERING\EA\BO1540-43\BO1540-43_SHT_35.DWG

Valves Located at JAL Cargo Building

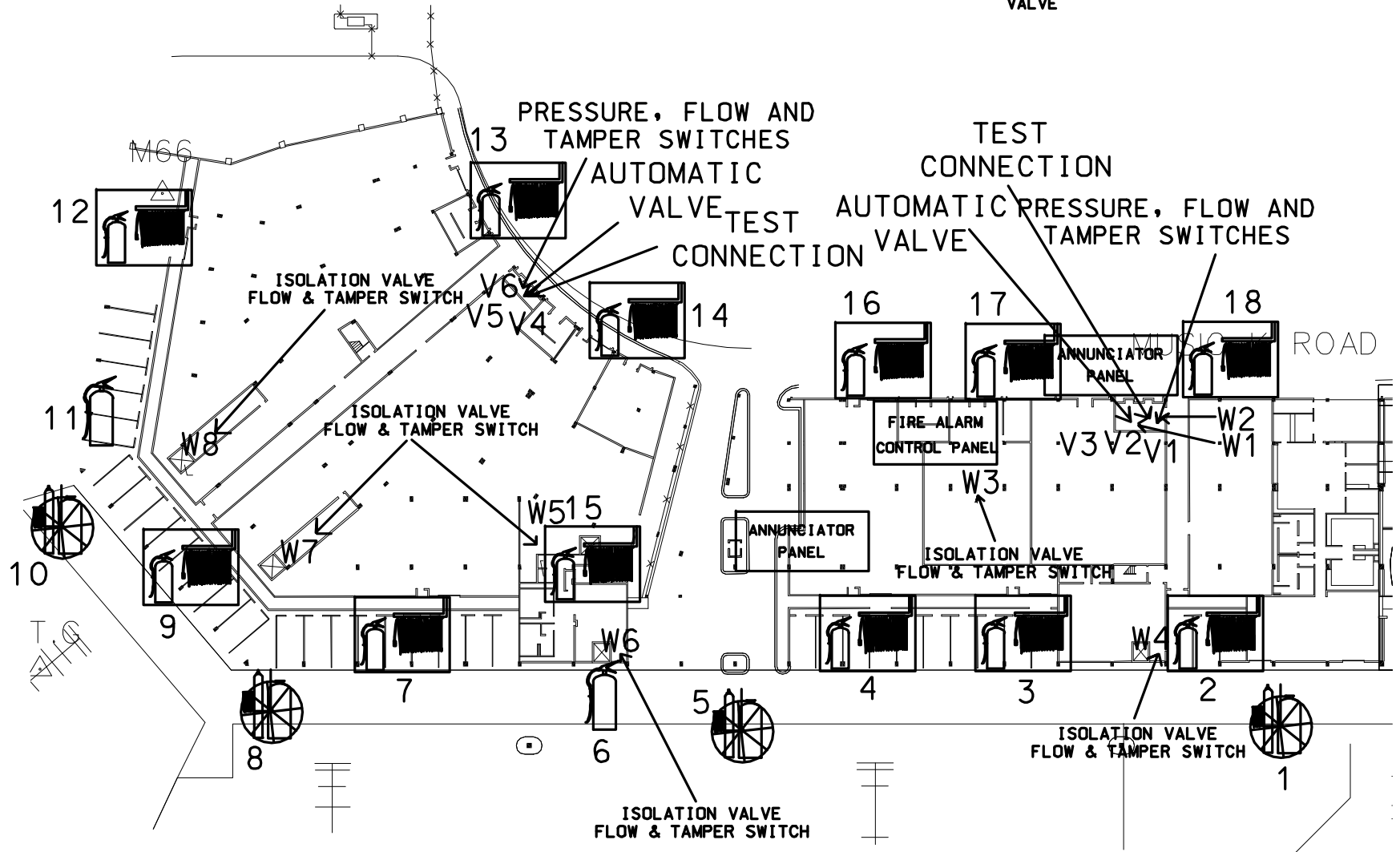

V8 AUTOMATIC VALVE
 V7 POST INDICATOR VALVE



HONOLULU INTERNATIONAL AIRPORT  Airports Division		Date : FEBRUARY 2018	EXHIBIT: 
EWA CONCOURSE EXTENSION G/F - RAMP AREA AND OFFICES		BO1542-43 Inspection and Maintenance of Airport Fire Protection Equipment	SHT 36 OF 62

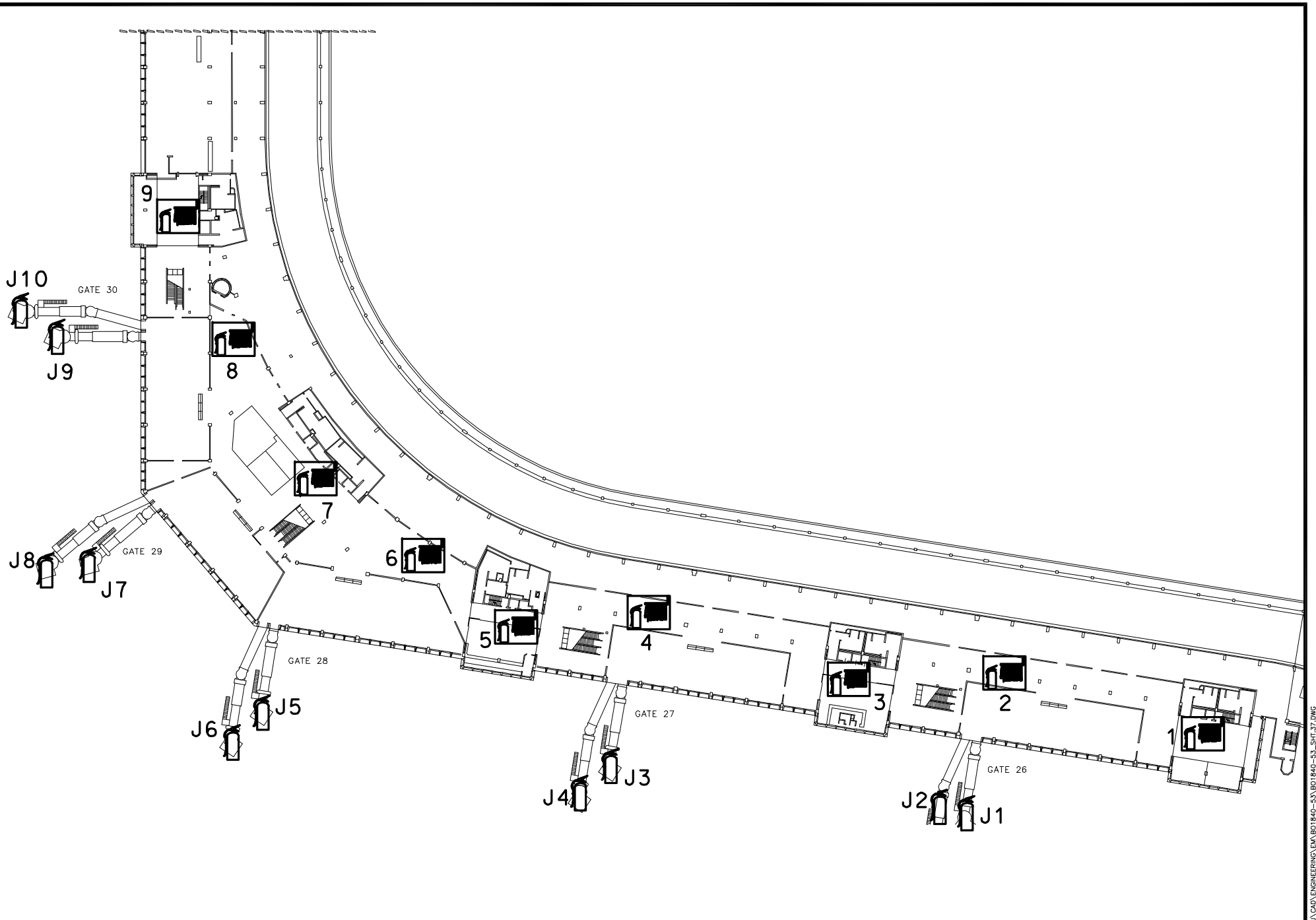

W:\AIRPORTS\HNL\HONOLULU CAD\ENGINEERING\EA\BO1540-43\BO1540-43_SHT_36.DWG



HONOLULU INTERNATIONAL AIRPORT  Airports Division		Date : FEBRUARY 2018	EXHIBIT: 
EWA CONCOURSE 2/F - GATE AREA		BO1542-43 Inspection and Maintenance of Airport Fire Protection Equipment	SHT 37 OF 62

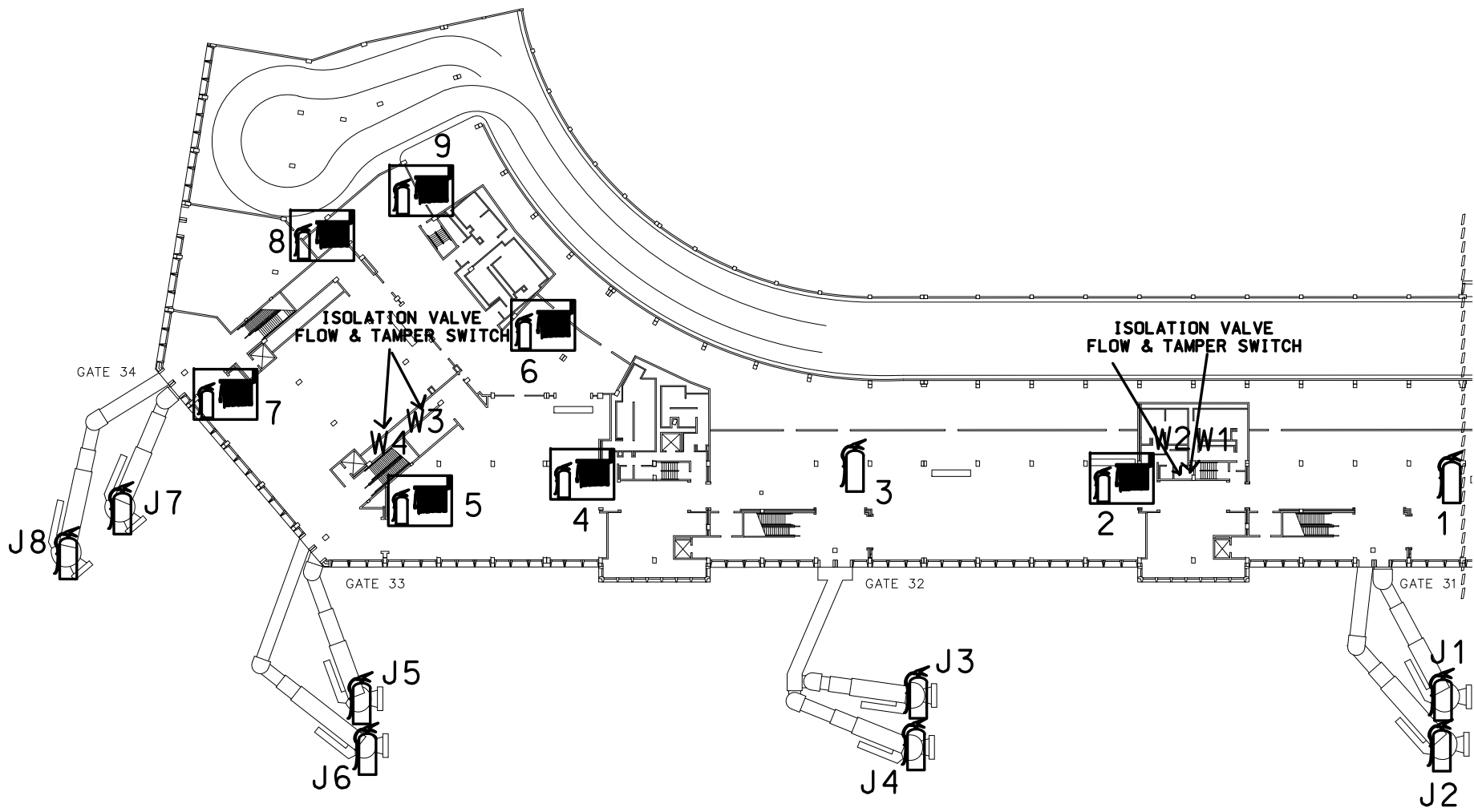

W:\AIRPORTS\HNL\HONOLULU CAD\ENGINEERING\EA\BO1540-53\BO1540-53_SHT_37.DWG

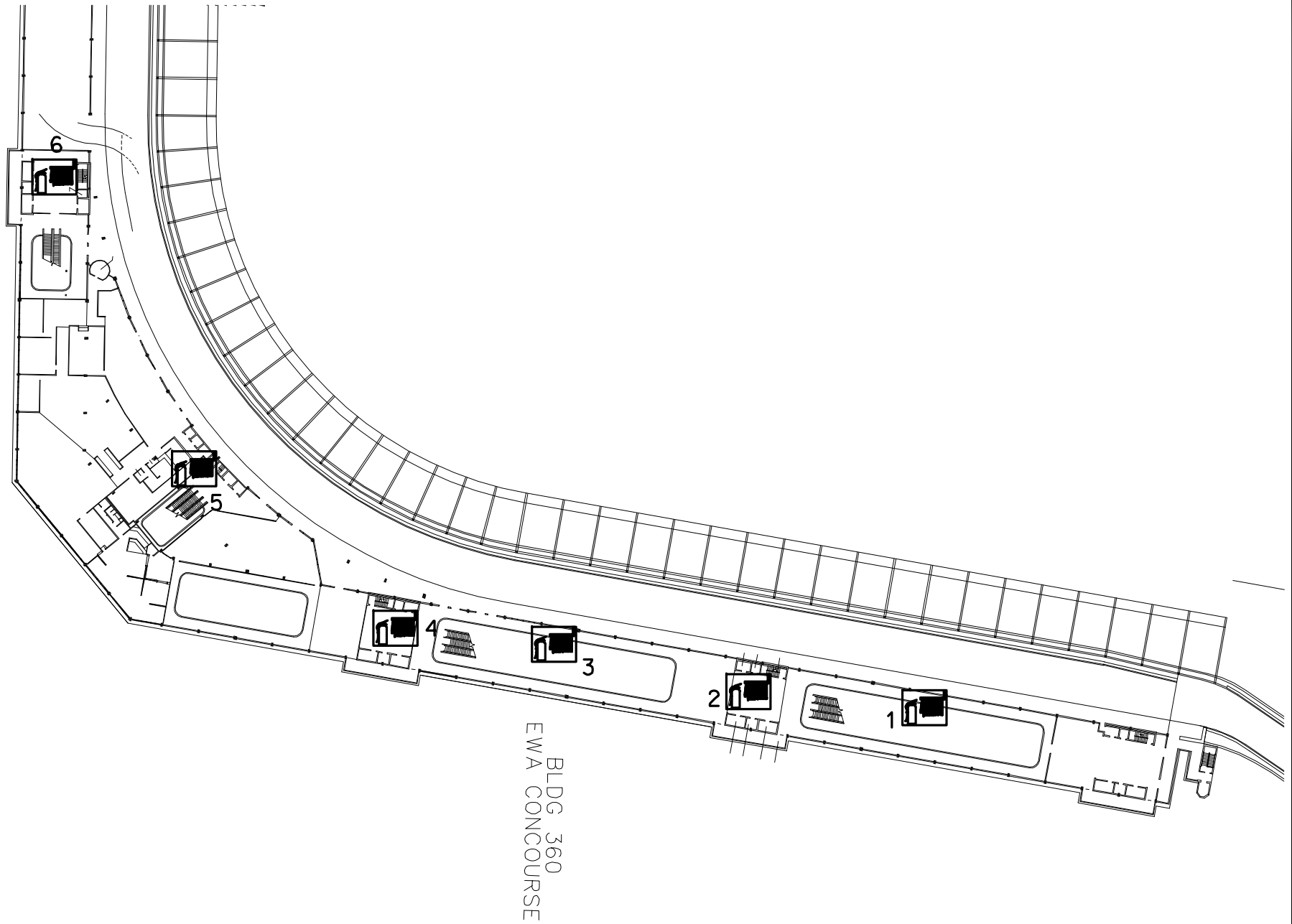

HONOLULU INTERNATIONAL AIRPORT  Airports Division		Date : FEBRUARY 2018	EXHIBIT: 
EWA CONCOURSE EXTENSION 2/F - GATE AREA		BO1542-43 Inspection and Maintenance of Airport Fire Protection Equipment	SHT 38 OF 62

N:\AIRPORTS\HNL\HONOLULU\CA\ENGINEERING\EM\BO1540-53\BO1540-53_SHT_38.DWG



		HONOLULU INTERNATIONAL AIRPORT Date : FEBRUARY 2018	EXHIBIT:  SHT 39 OF 62
EWA CONCOURSE THIRD FLOOR		BO1542-43 Inspection and Maintenance of Airport Fire Protection Equipment	

W:\AIRPORTS\HNL\HONOLULU\CAD\ENGINEERING\EM\BO1540-43\BO1540-43_SHT_39.DWG

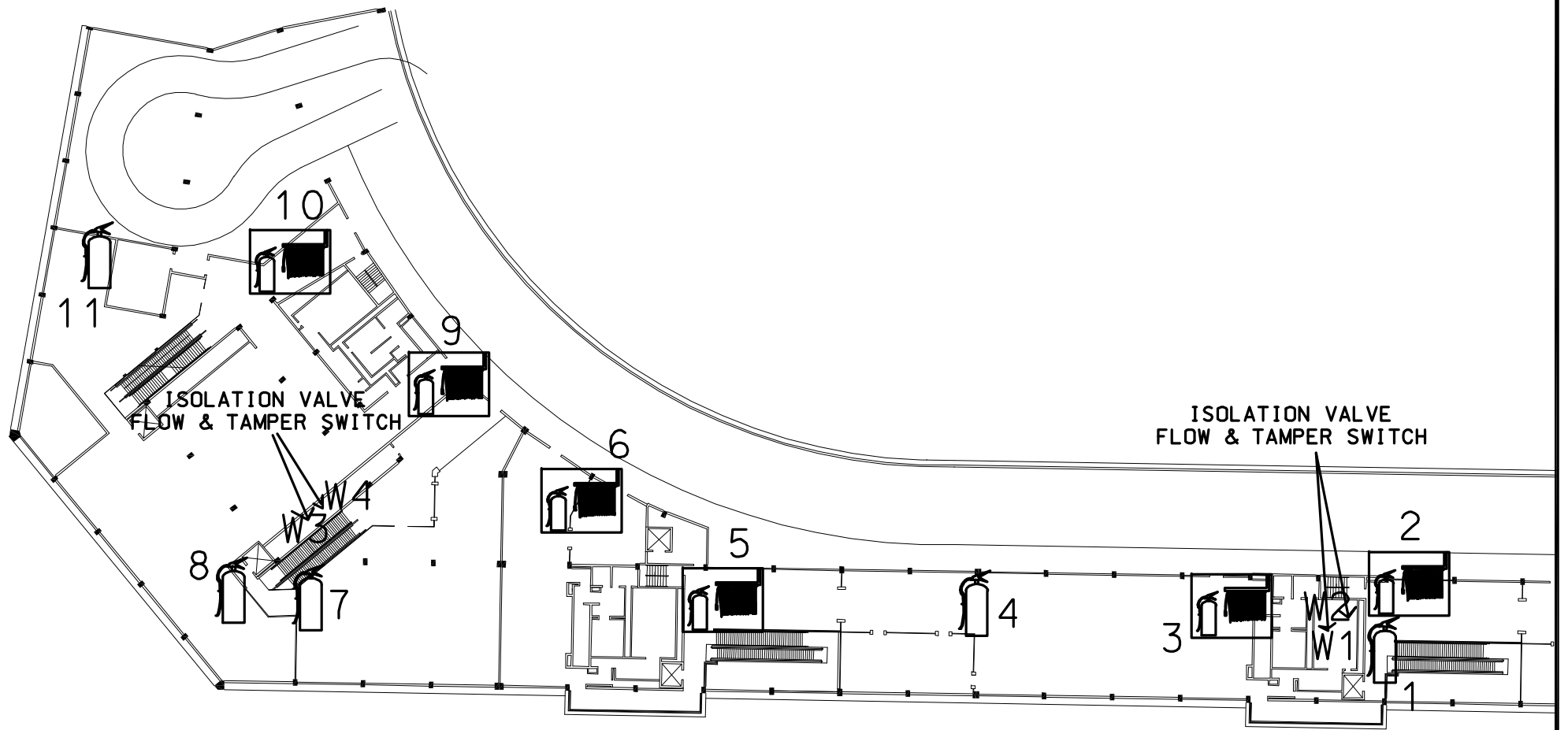

BLDG 368
EWA CONCOURSE EXTENSION

HONOLULU INTERNATIONAL AIRPORT  Airports Division		Date : FEBRUARY 2018	EXHIBIT: 
EWA CONCOURSE EXTENSION THIRD FLOOR		BO1542-43 Inspection and Maintenance of Airport Fire Protection Equipment	SHT 40 OF 62

W:\AIRPORTS\HNL_HONOLULU\CAD\ENGINEERING\EM\BO1540-53\BO1540-53_SHT_40.DWG

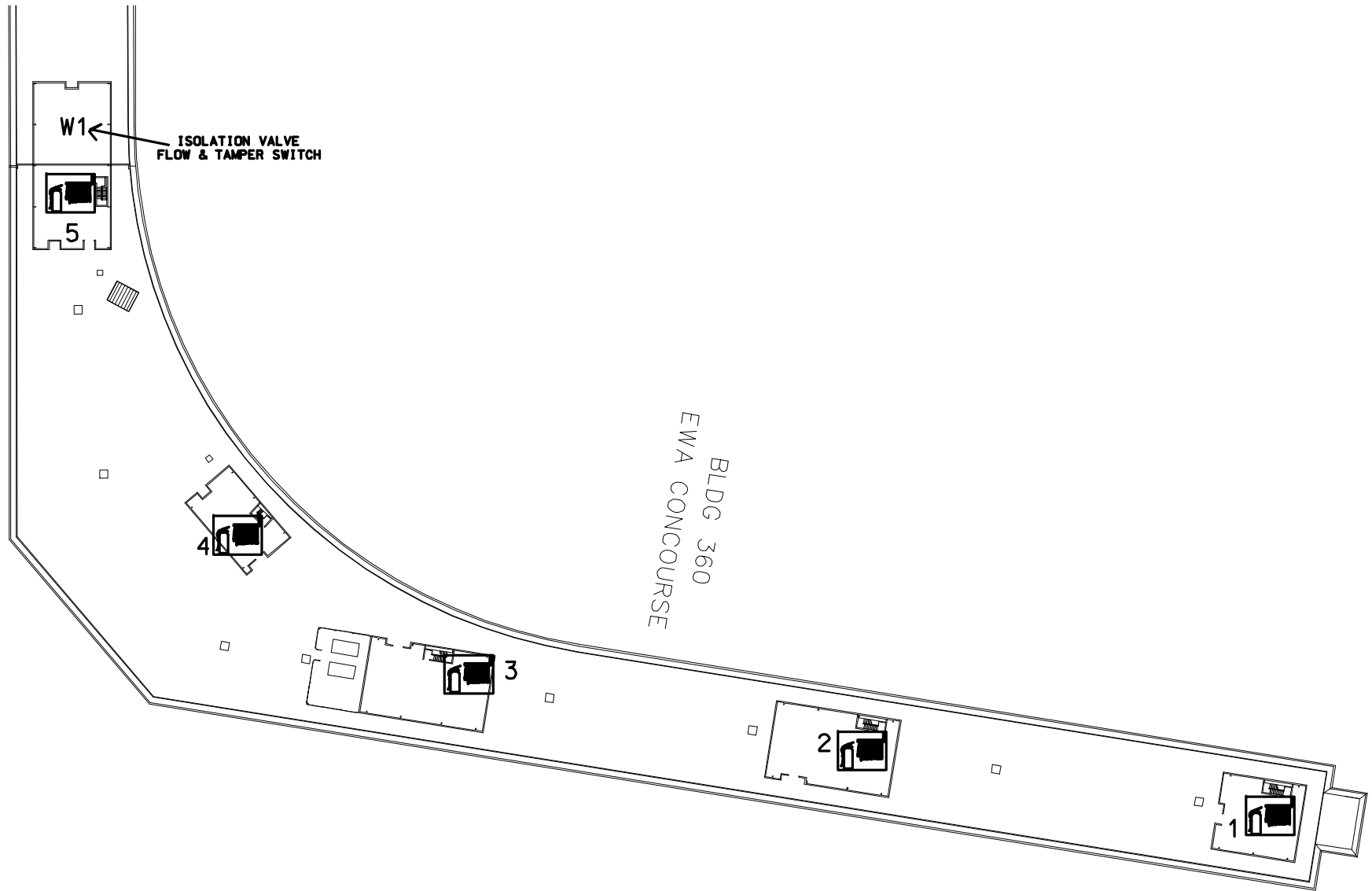

HONOLULU INTERNATIONAL AIRPORT

Date : FEBRUARY 2018

EXHIBIT:



**EWA CONCOURSE
4/F - ROOF AREA**



**BO1542-43 Inspection and
Maintenance of Airport Fire
Protection Equipment**

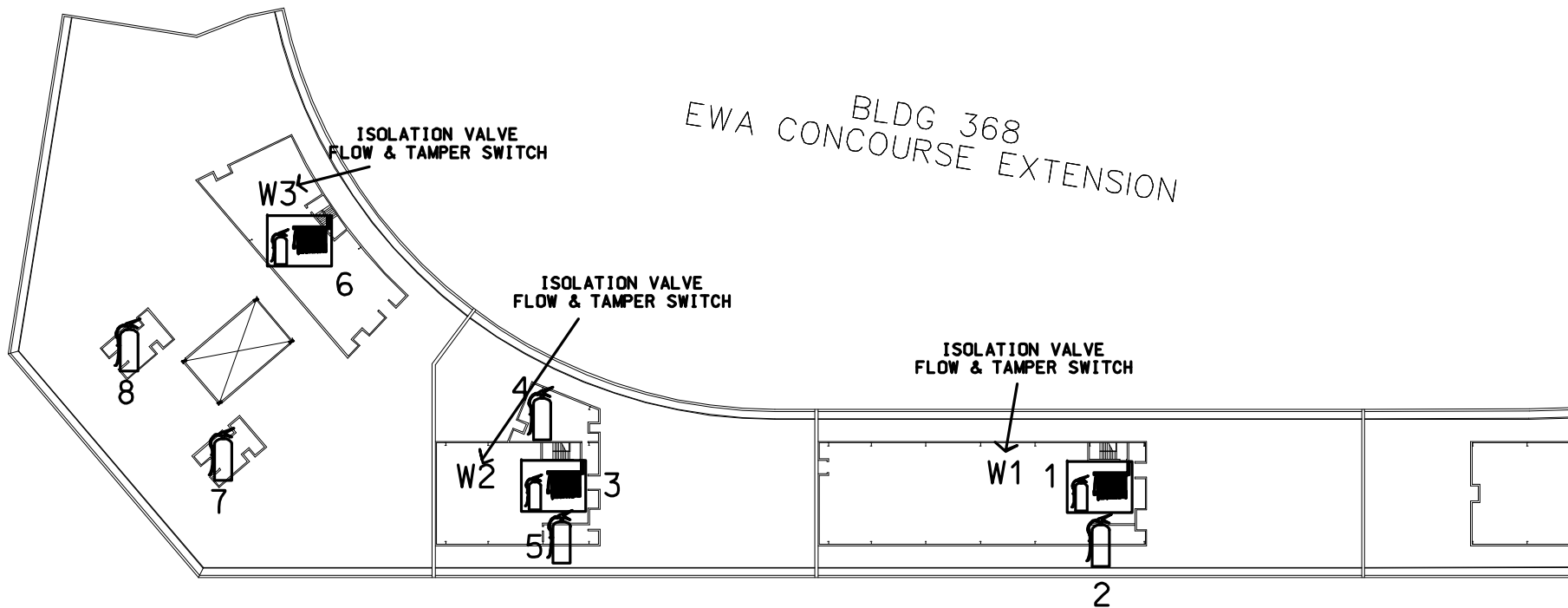

SHT 41 OF 62

N:\AIRPORTS\HNL\HONOLULU\CAD\ENGINEERING\EM\BO1540-53\BO1540-53_SHT_41.DWG



HONOLULU INTERNATIONAL AIRPORT  Airports Division		Date : FEBRUARY 2018	EXHIBIT:  SHT 42 OF 62
EWA CONCOURSE EXTENSION 4/F - ROOF AREA		BO1542-43 Inspection and Maintenance of Airport Fire Protection Equipment	

W:\AIRPORTS\HNL\HONOLULU CAD\ENGINEERING\EWA\BO1540-53\BO1540-53_SHT.42.DWG

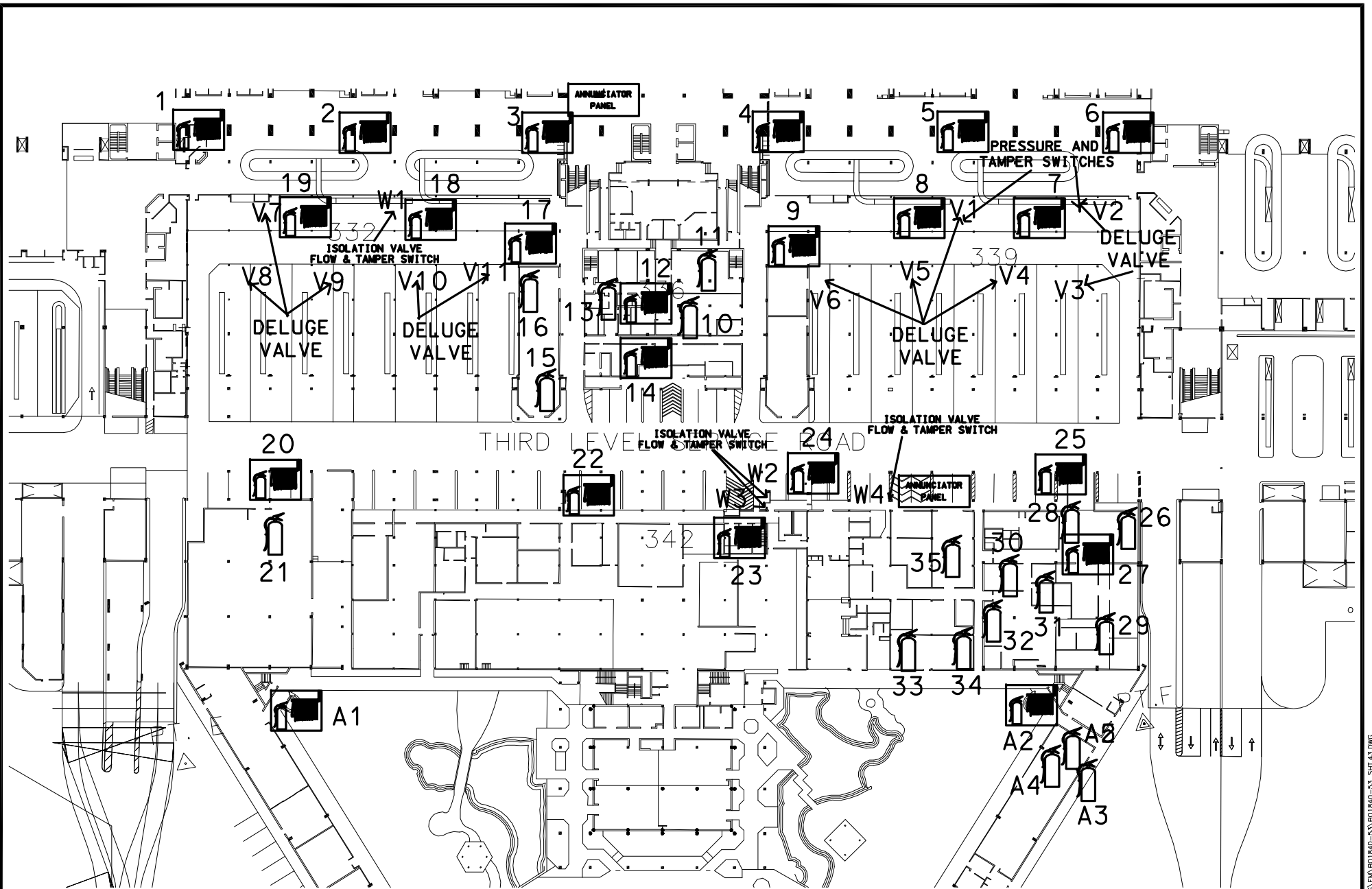

HONOLULU INTERNATIONAL AIRPORT 		Date : FEBRUARY 2018	EXHIBIT: 
MAIN TERMINAL BUILDING GROUND FLOOR		BO1542-43 Inspection and Maintenance of Airport Fire Protection Equipment	SHT 43 OF 62

W:\AIRPORTS\HNL_HONOLULU CAD\ENGINEERING\EA\BO1540-53\BO1540-53_SHT_A3.DWG

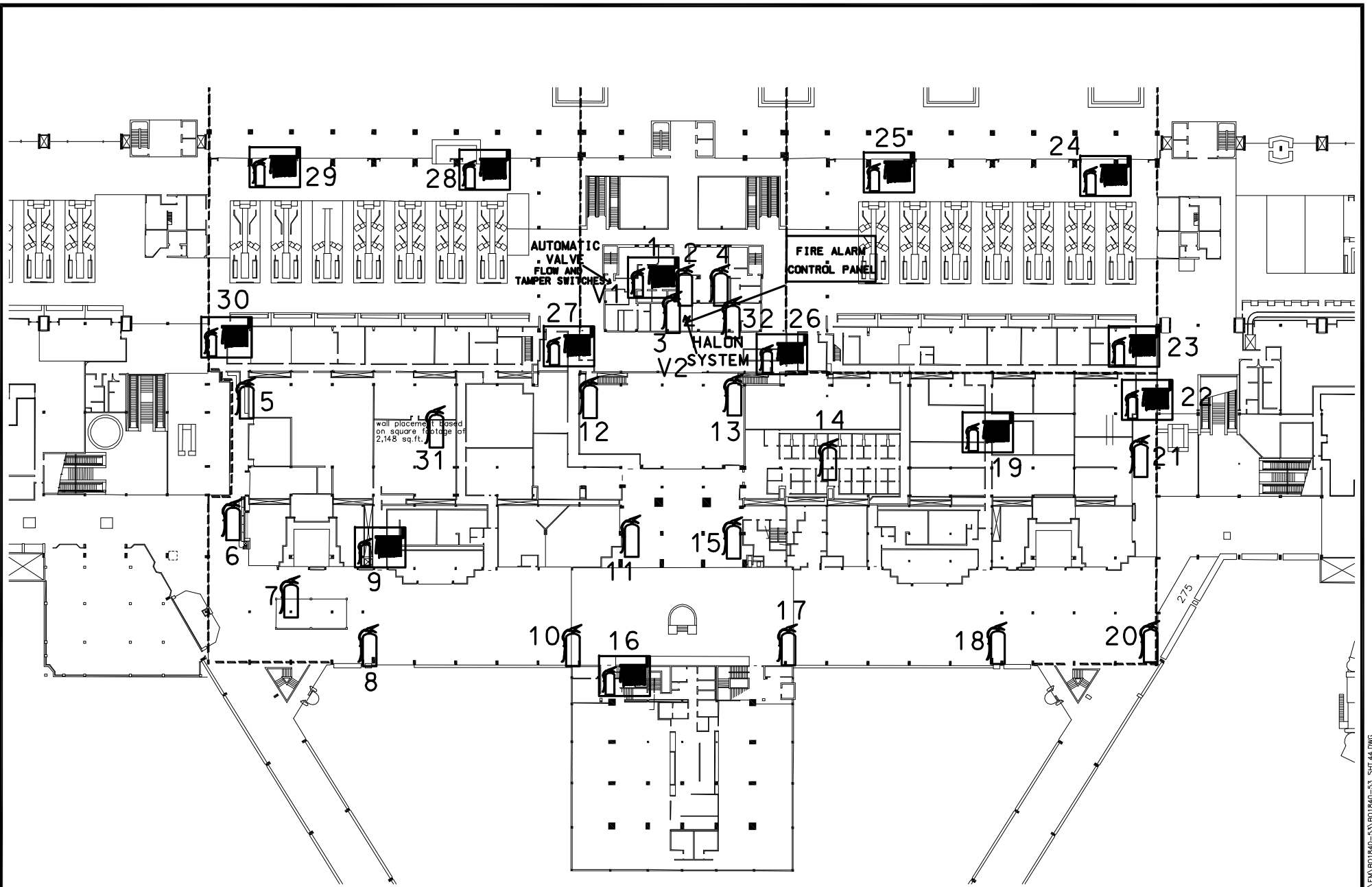

HONOLULU INTERNATIONAL AIRPORT  Airports Division		Date : FEBRUARY 2018	EXHIBIT: 
MAIN TERMINAL BUILDING SECOND FLOOR		BO1542-43 Inspection and Maintenance of Airport Fire Protection Equipment	SHT 44 OF 62

W:\AIRPORTS\HNL_HONOLULU CAD\ENGINEERING\EA\BO1540-53\BO1540-53_SHT_44.DWG

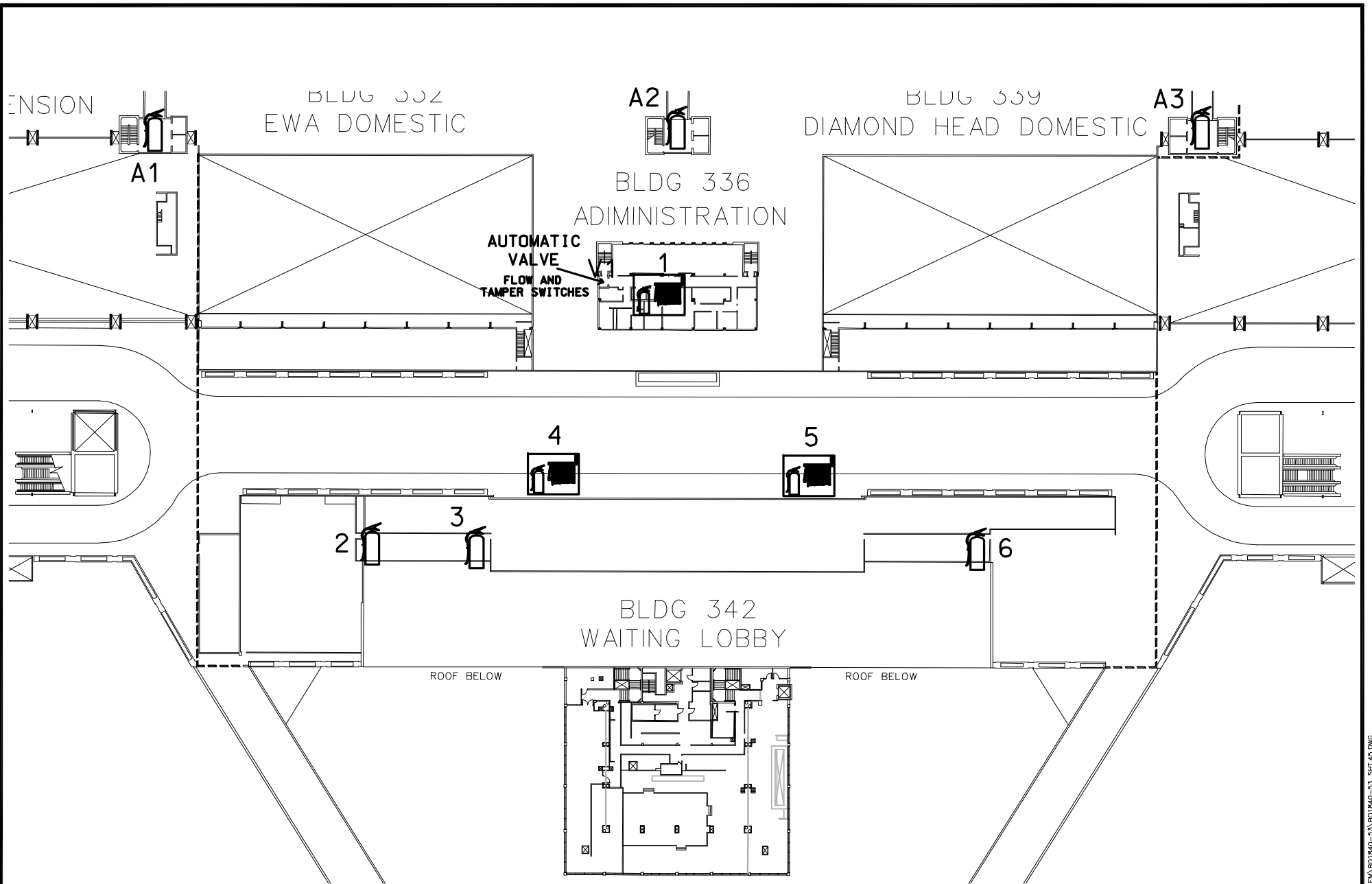

HONOLULU INTERNATIONAL AIRPORT  Airports Division		Date : FEBRUARY 2018	EXHIBIT: 
MAIN TERMINAL BUILDINGS THIRD FLOOR		BO1542-43 Inspection and Maintenance of Airport Fire Protection Equipment	SHT 45 OF 62

W:\AIRPORTS\HNL_HONOLULU\CAD\ENGINEERING\EA\BO1540-43\BO1540-43_SHT_45.DWG

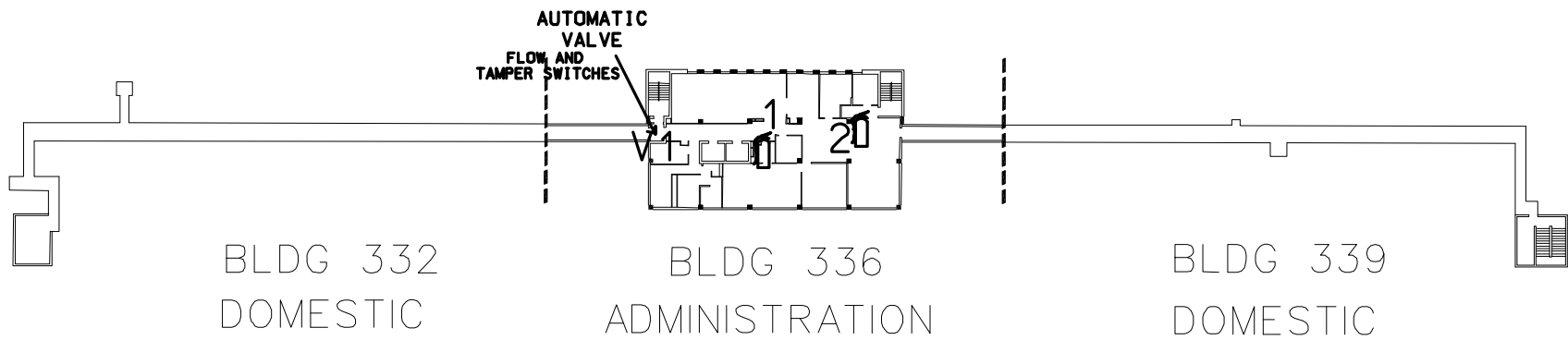

HONOLULU INTERNATIONAL AIRPORT		Date : FEBRUARY 2018	EXHIBIT:
 Airports Division	MAIN TERMINAL 4/F - ADMIN. BUILDING	BO1542-43 Inspection and Maintenance of Airport Fire Protection Equipment	 SHT 46 OF 62

AUTOMATIC
VALVE
FLOW AND
TAMPER SWITCHES

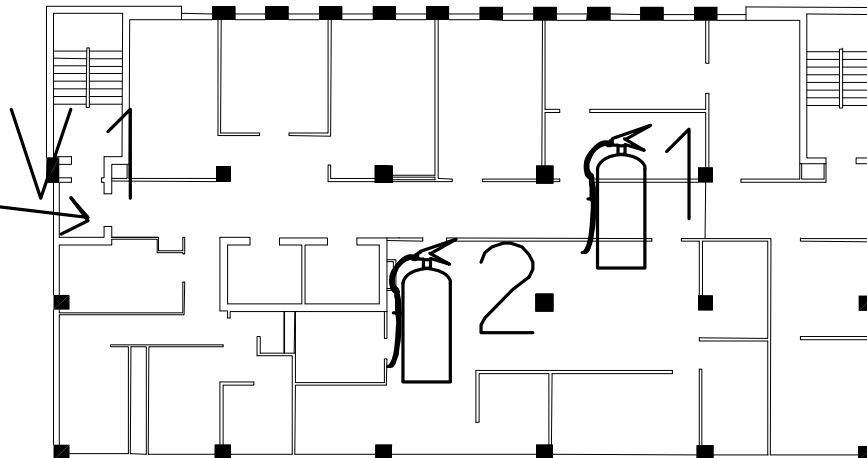

HONOLULU INTERNATIONAL AIRPORT

Date : FEBRUARY 2018

EXHIBIT:



Airports Division

ADMINISTRATION BUILDING
FIFTH FLOOR

BO1542-43 Inspection and
Maintenance of Airport Fire
Protection Equipment



SHT 47 OF 62

AUTOMATIC
VALVE
FLOW AND
TAMPER SWITCHES

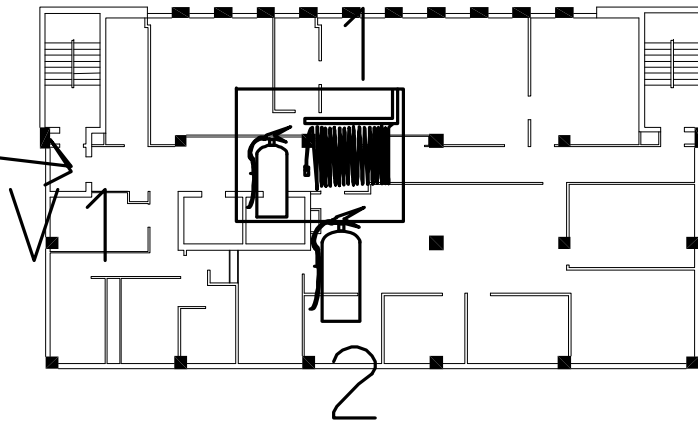

HONOLULU INTERNATIONAL AIRPORT

Date : FEBRUARY 2018

EXHIBIT:



Airports Division

ADMINISTRATION BUILDING
SIXTH FLOOR

BO1542-43 Inspection and
Maintenance of Airport Fire
Protection Equipment



SHT 48 OF 62

AUTOMATIC
VALVE
FLOW AND
TAMPER SWITCHES

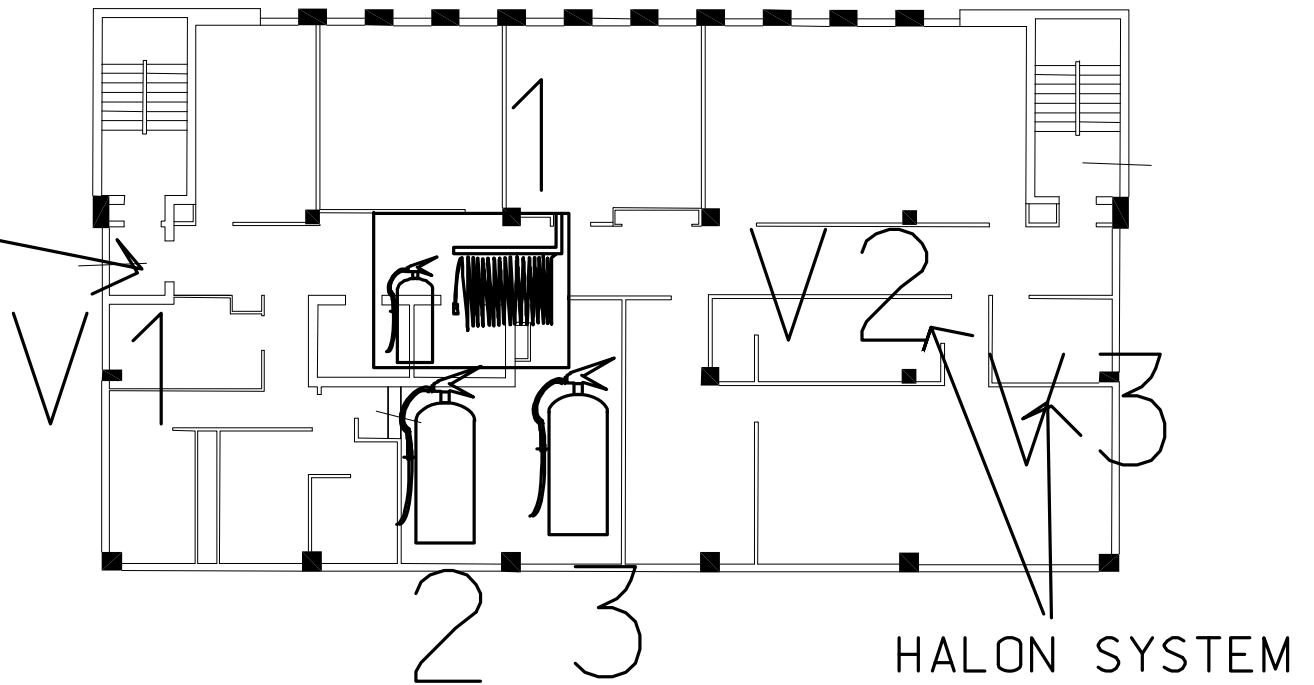

HONOLULU INTERNATIONAL AIRPORT

Date : FEBRUARY 2018



Airports Division

ADMINISTRATION BUILDING
SEVENTH FLOOR

BO1542-43 Inspection and
Maintenance of Airport Fire
Protection Equipment



EXHIBIT:

A

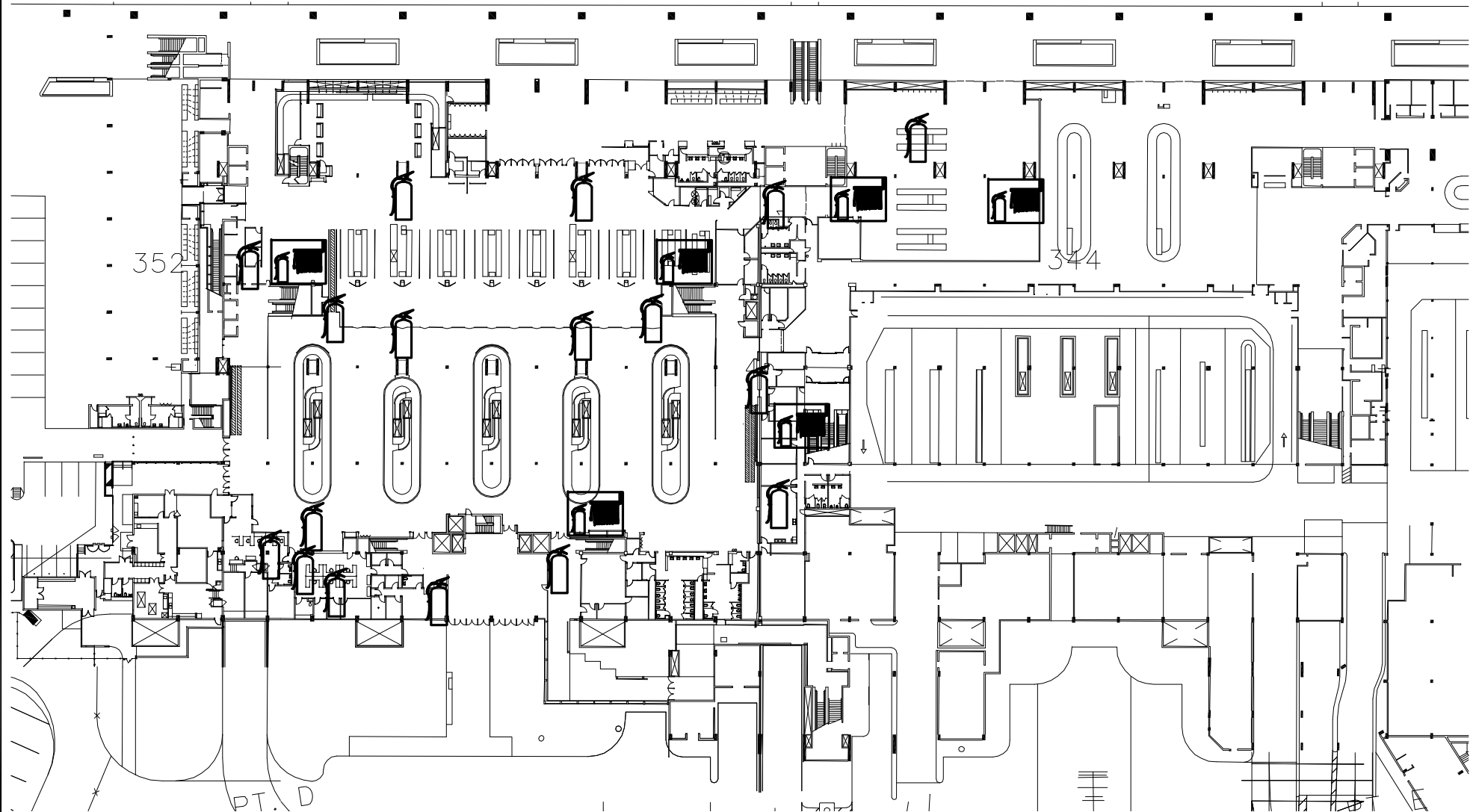
SHT 49 OF 62



A

HONOLULU INTERNATIONAL AIRPORT  Airports Division		Date : FEBRUARY 2018	EXHIBIT: 
EWA EXTENSION GROUND FLOOR		BO1542-43 Inspection and Maintenance of Airport Fire Protection Equipment	A SHT 50 OF 62

W:\AIRPORTS\HNL_HONOLULU\CAD\ENGINEERING\EA\BO1540-43\BO1540-43_SHT_50.DWG

BLDG 336 ADMINISTRATION BUILDING

AUTOMATIC
VALVE
FLOW AND
TAMPER SWITCHES

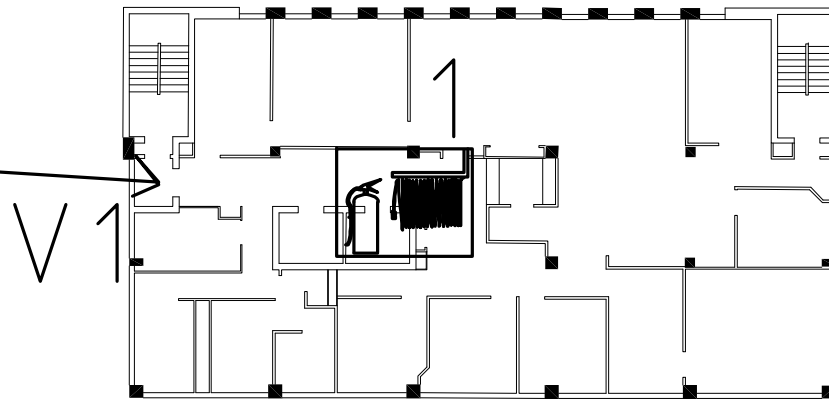

HONOLULU INTERNATIONAL AIRPORT



Airports Division

ADMINISTRATION BUILDING
EIGHTH FLOOR

Date : FEBRUARY 2018

BO1542-43 Inspection and
Maintenance of Airport Fire
Protection Equipment

EXHIBIT:



SHT 51 OF 62

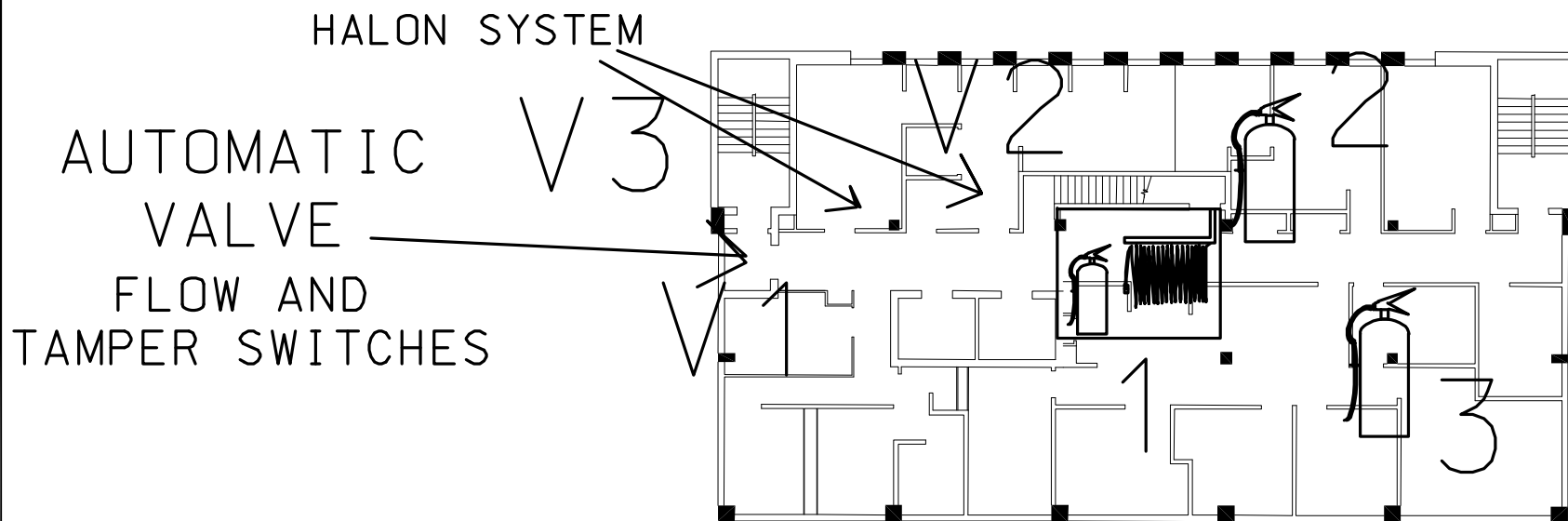

HONOLULU INTERNATIONAL AIRPORT  Airports Division		ADMINISTRATION BUILDING NINTH FLOOR	Date : FEBRUARY 2018 BO1542-43 Inspection and Maintenance of Airport Fire Protection Equipment	EXHIBIT:  SHT 52 OF 62
---	--	--	---	---

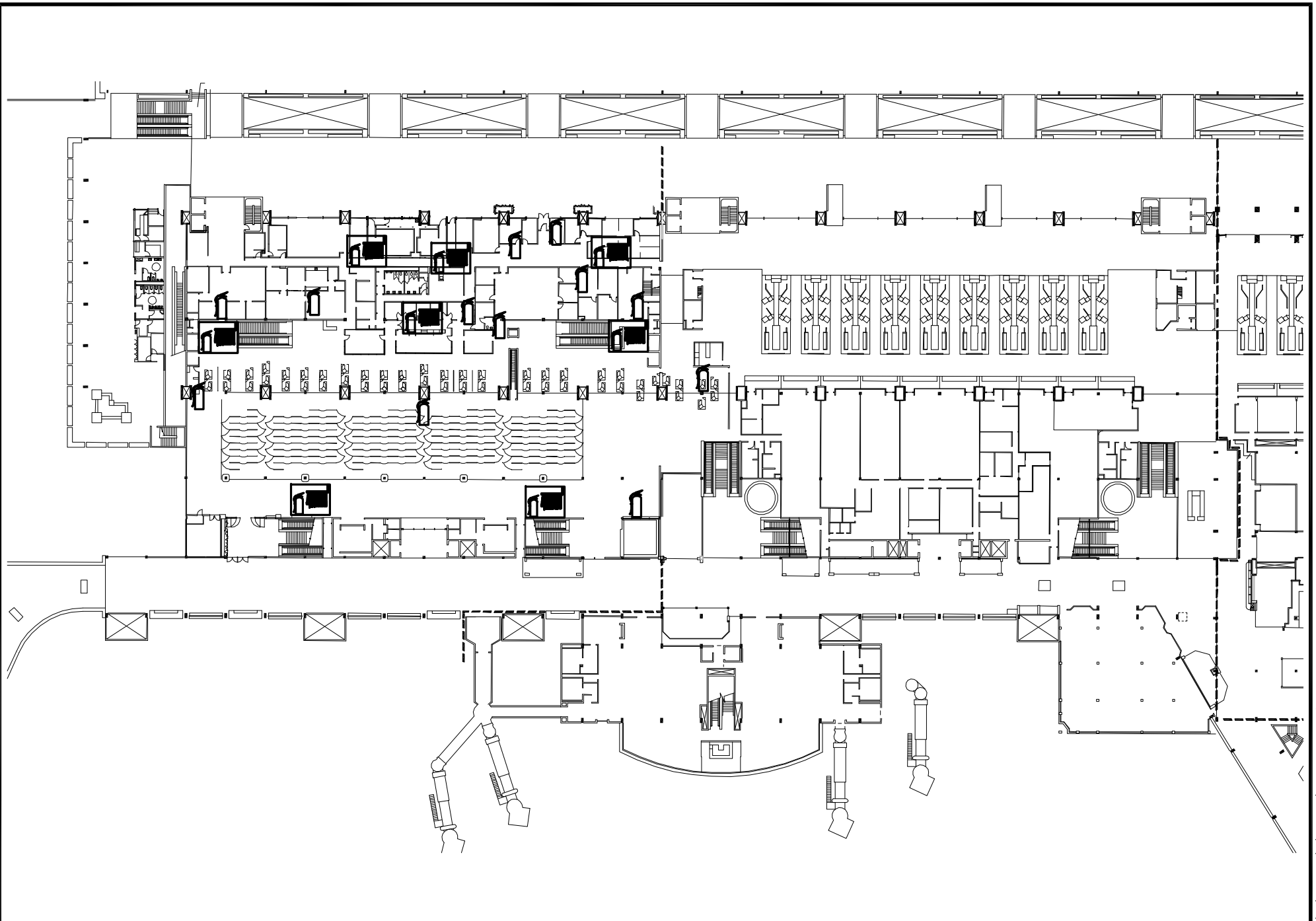

HONOLULU INTERNATIONAL AIRPORT  Airports Division		EWA EXTENSION BUILDINGS SECOND FLOOR	Date : FEBRUARY 2018 BO1542-43 Inspection and Maintenance of Airport Fire Protection Equipment	EXHIBIT:  SHT 53 OF 62
---	--	---	--	---

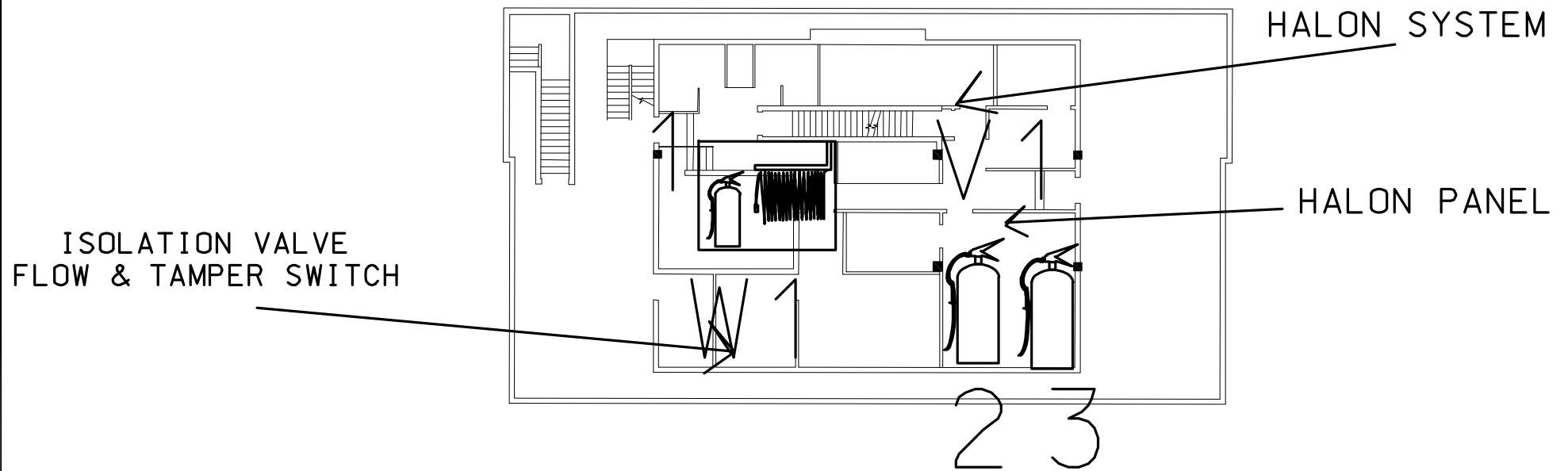

W:\AIRPORTS\HNL_HONOLULU\CAD\ENGINEERING\EM\BO1540-53\BO1540-53_SHT_53.DWG

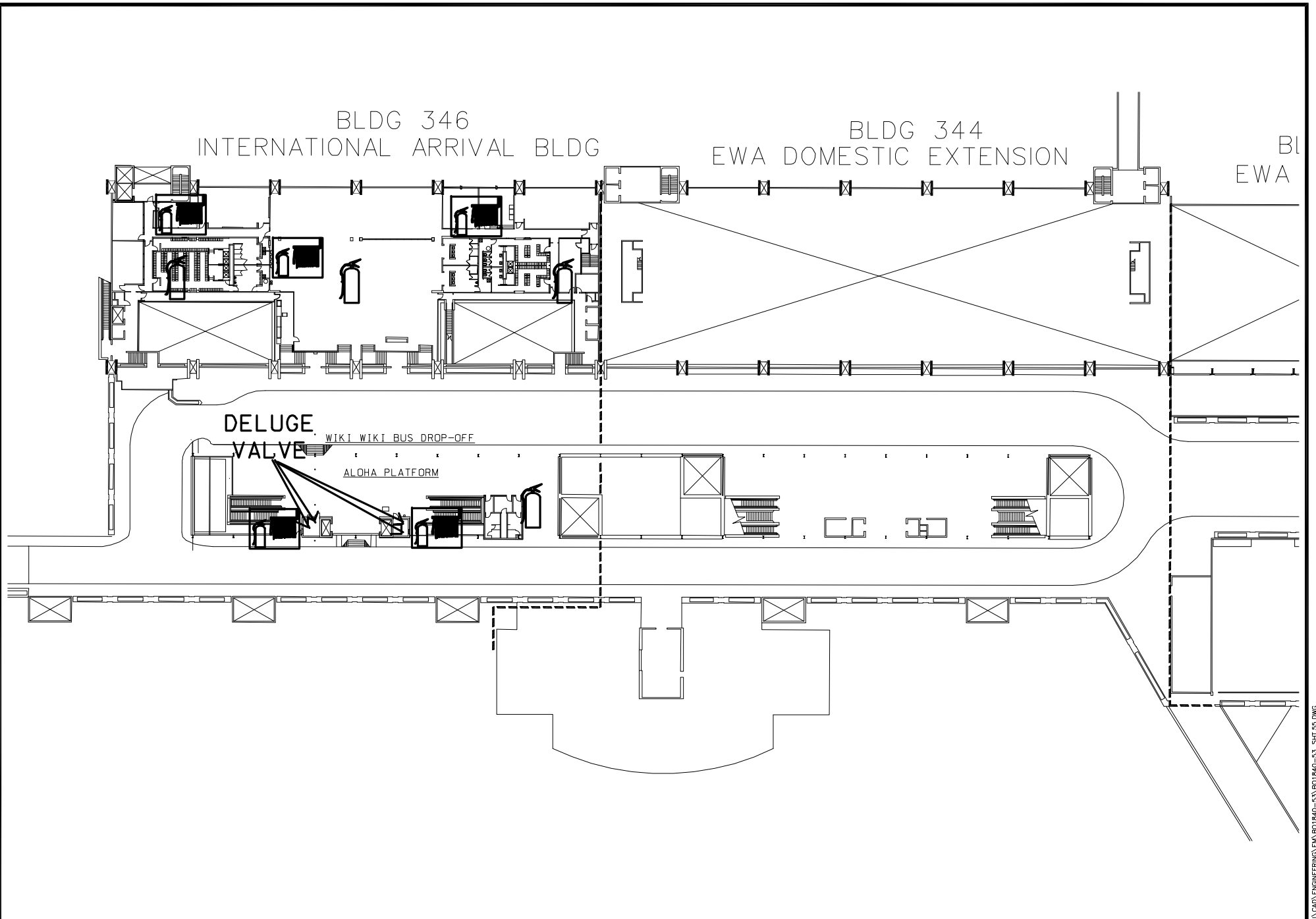

HONOLULU INTERNATIONAL AIRPORT  Airports Division		Date : FEBRUARY 2018	EXHIBIT: 
ADMINISTRATION BUILDING TENTH FLOOR		BO1542-43 Inspection and Maintenance of Airport Fire Protection Equipment	SHT 54 OF 62

W:\AIRPORTS\HNL_HONOLULU_CAD\ENGINEERING\EM\BO1540-53\BO1540-53_SHT_54.DWG



HONOLULU INTERNATIONAL AIRPORT  Airports Division		Date : FEBRUARY 2018	EXHIBIT: 
EWA EXTENSION THIRD FLOOR		BO1542-43 Inspection and Maintenance of Airport Fire Protection Equipment	SHT 55 OF 62

W:\AIRPORTS\HNL_HONOLULU CAD\ENGINEERING\EM\BO1540-43\BO1540-43_SHT_55.DWG

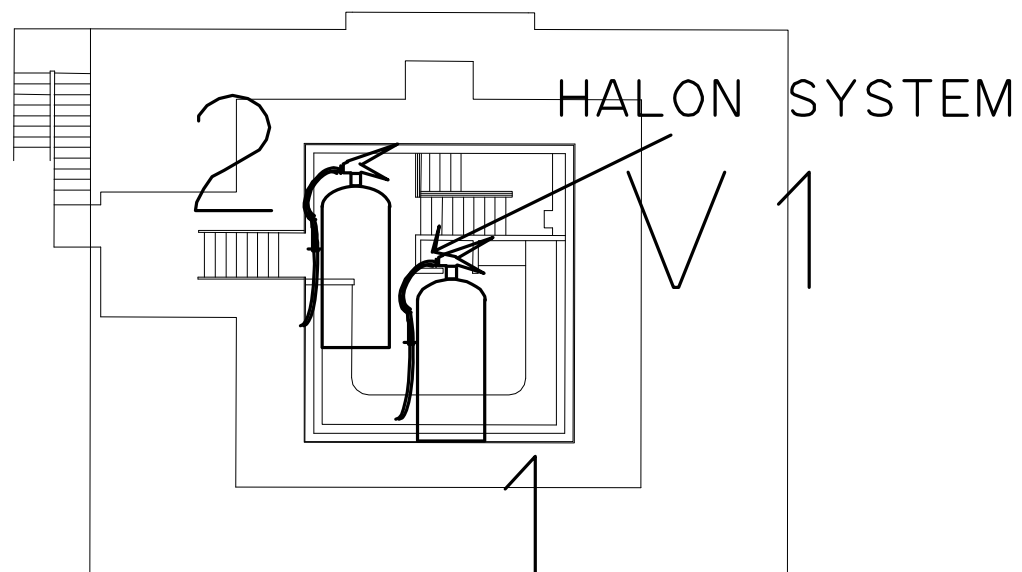

HONOLULU INTERNATIONAL AIRPORT

Date : FEBRUARY 2018

EXHIBIT:



Airports Division

RAMP CONTROL CAB
ADMINISTRATION BUILDING
ELEVENTH FLOOR

BO1542-43 Inspection and
Maintenance of Airport Fire
Protection Equipment



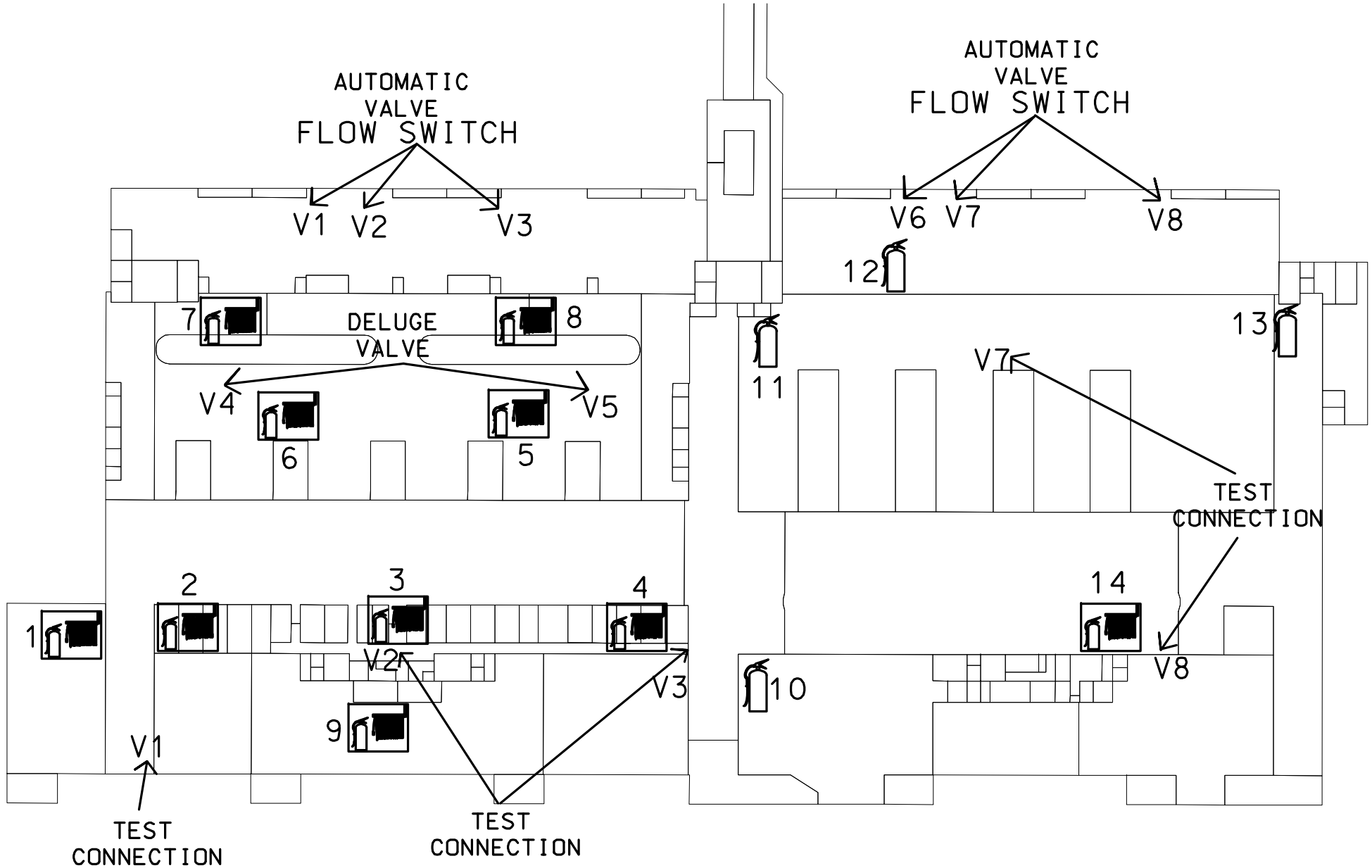

SHT 56 OF 62



HONOLULU INTERNATIONAL AIRPORT  Airports Division		Date : FEBRUARY 2018	EXHIBIT: 
DIAMOND HEAD EXTENSION BASEMENT LEVEL		BO1542-43 Inspection and Maintenance of Airport Fire Protection Equipment	A SHT 57 OF 62

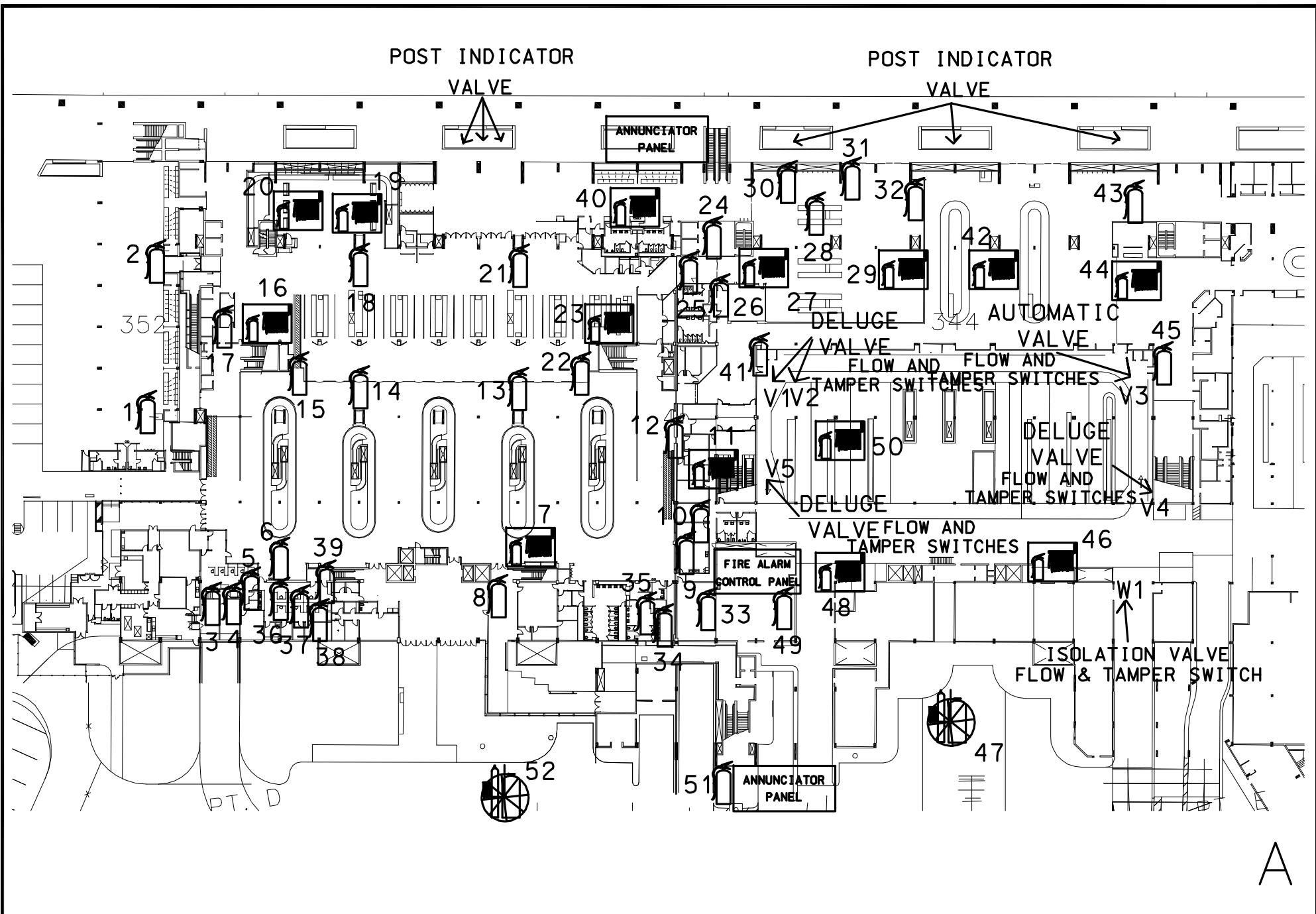

W:\AIRPORTS\HNL_HONOLULU\CAD\ENGINEERING\EM\BO1540-43\BO1540-43_SHT.57.DWG



HONOLULU INTERNATIONAL AIRPORT  Airports Division		Date : FEBRUARY 2018	EXHIBIT: 
EWA EXTENSION GROUND FLOOR		BO1542-43 Inspection and Maintenance of Airport Fire Protection Equipment	SHT 58 OF 62

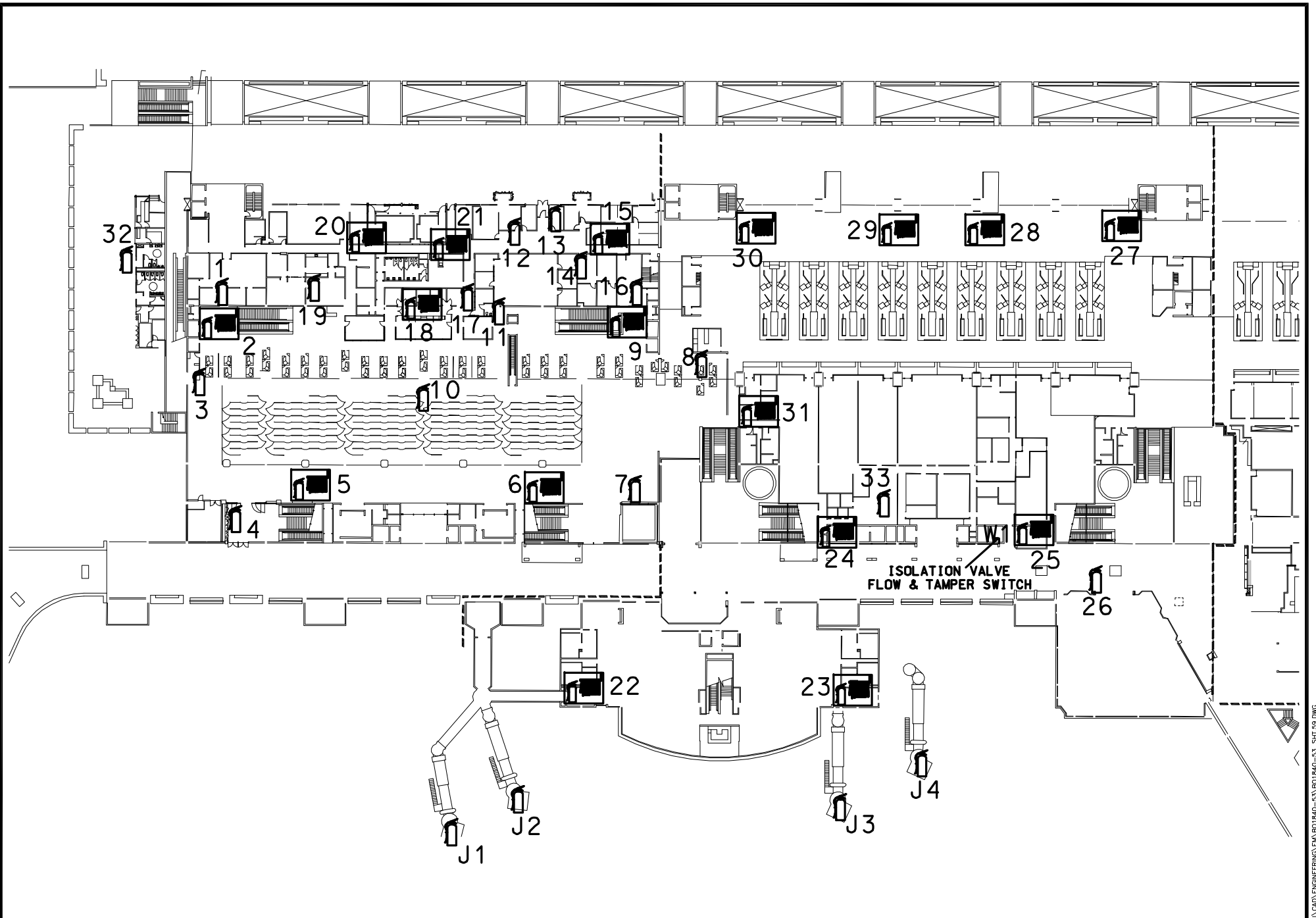

H:\AIRPORTS\HNL_HONOLULU\CAD\ENGINEERING\EA\BO1540-53\BO1540-53_SHT_58.DWG

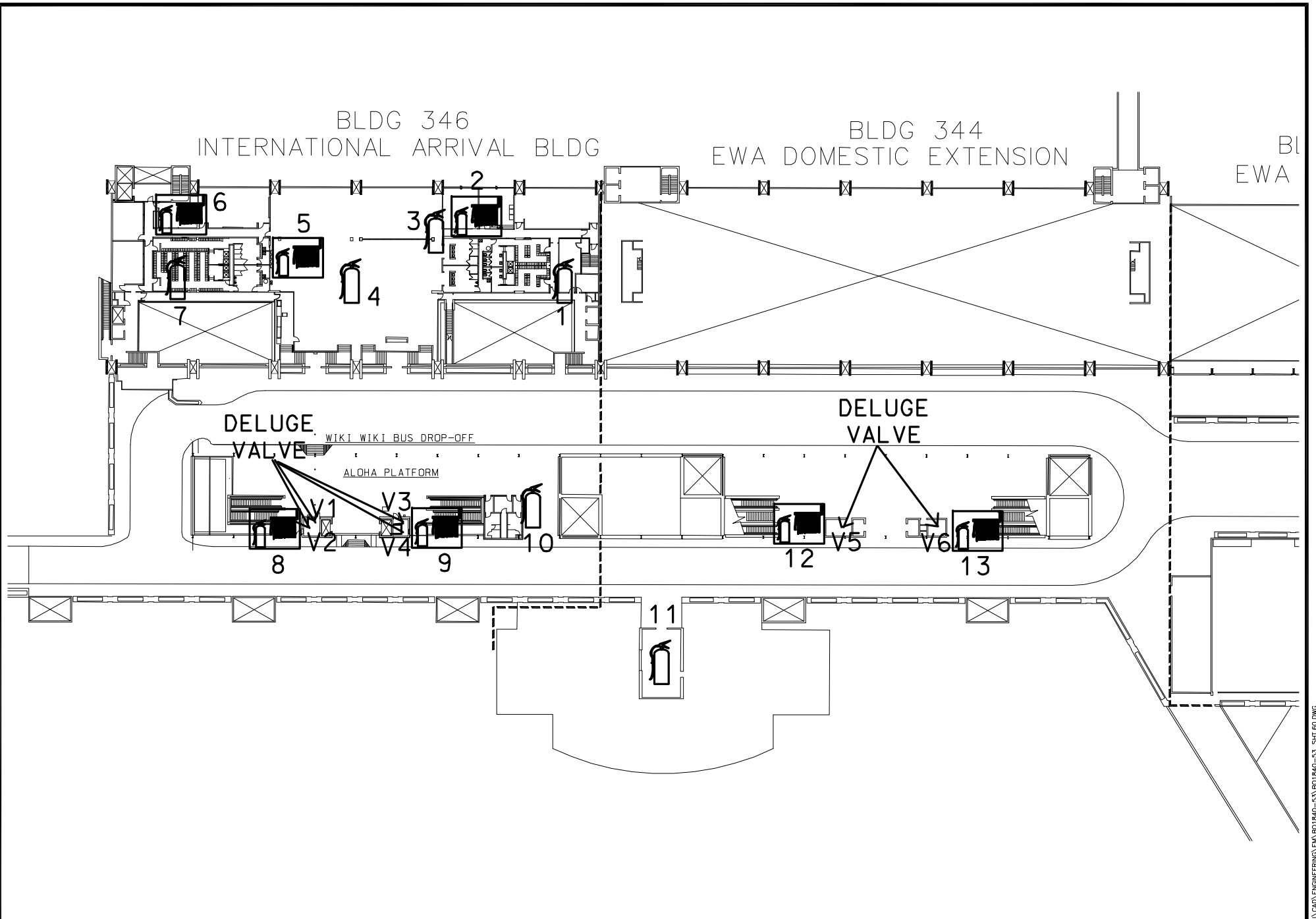

HONOLULU INTERNATIONAL AIRPORT  Airports Division		Date : FEBRUARY 2018 EWA EXTENSION SECOND LEVEL	BO1542-43 Inspection and Maintenance of Airport Fire Protection Equipment	EXHIBIT:  SHT 59 OF 62
---	--	--	--	---

W:\AIRPORTS\HNL_HONOLULU\CAD\ENGINEERING\EA\BO1540-43\BO1540-43_SHT_59.DWG



HONOLULU INTERNATIONAL AIRPORT  Airports Division		Date : FEBRUARY 2018	EXHIBIT:  SHT 60 OF 62
EWA EXTENSION THIRD FLOOR		BO1542-43 Inspection and Maintenance of Airport Fire Protection Equipment	

W:\AIRPORTS\HNL_HONOLULU CAD\ENGINEERING\EA\BO1540-43\BO1540-43_SHT_60.DWG

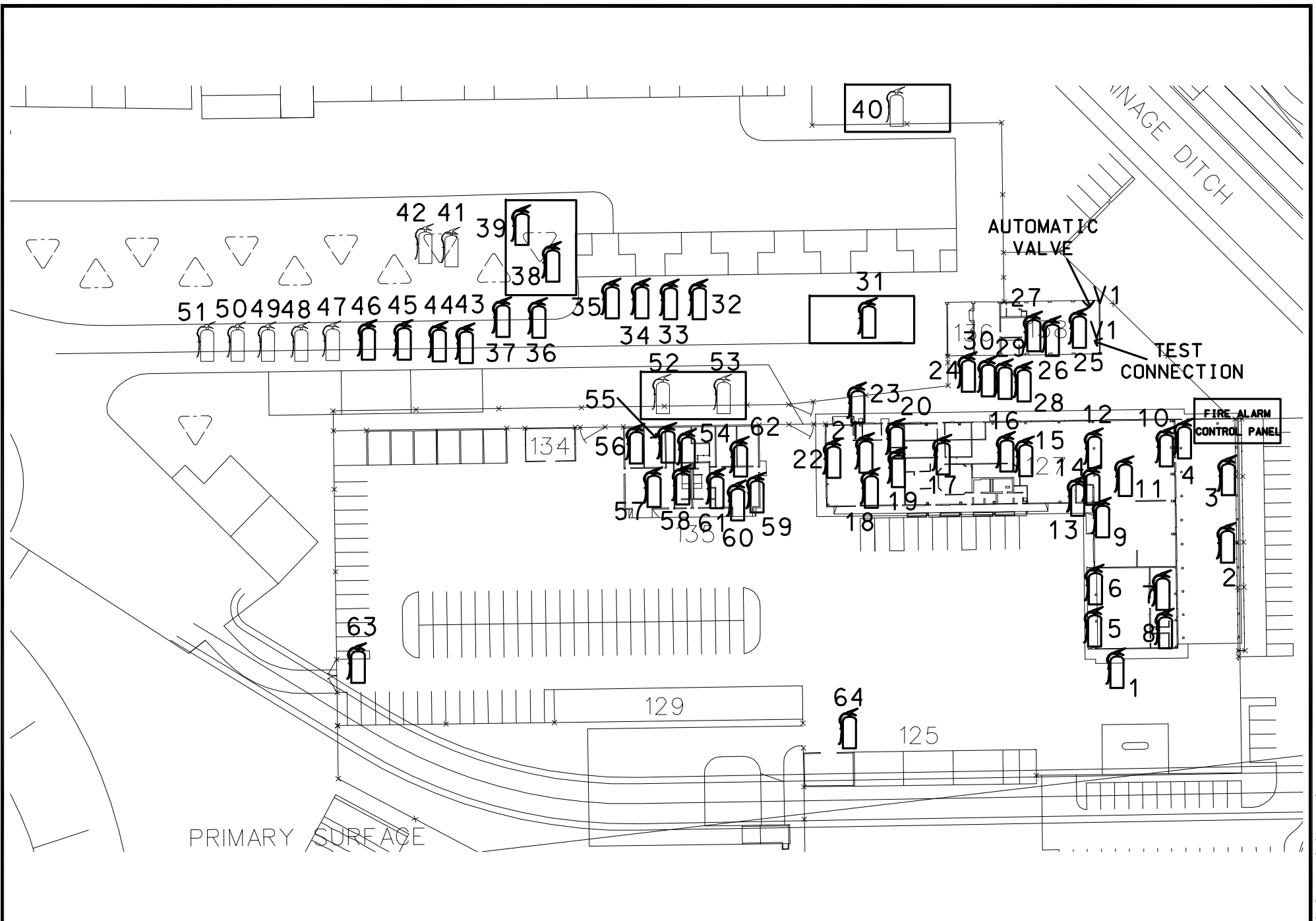



HONOLULU INTERNATIONAL AIRPORT  Airports Division		Date : FEBRUARY 2018	EXHIBIT:  SHT 61 OF 62
MAINTENANCE BASEYARD - G/F OFFICE BUILDINGS, TRAILERS AND VEHICLE LOCATIONS		BO1542-43 Inspection and Maintenance of Airport Fire Protection Equipment	

H:\AIRPORTS\HNL_HONOLULU\CAD\ENGINEERING\EA\BO1540-53\BO1540-53_SHT.61.DWG

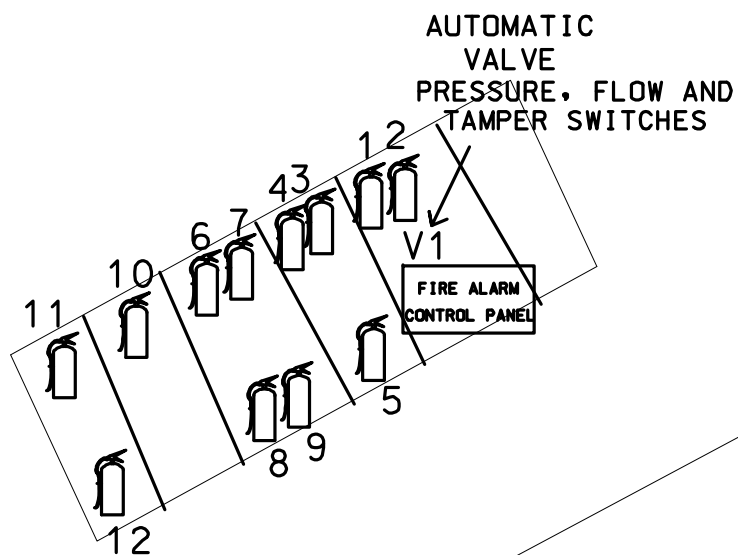
ELECTRIC VAULT "X"



HONOLULU INTERNATIONAL AIRPORT  Airports Division		Date : FEBRUARY 2018	EXHIBIT:
VAULT 'X' BY FAA TOWER - G/F OFFICE & BUILDING LOCATIONS		BO1542-43 Inspection and Maintenance of Airport Fire Protection Equipment	 SHT 62 OF 62

W:\AIRPORTS\HNL_HONOLULU\CAD\ENGINEERING\EA\BO1540-43\BO1540-43_SHT_62.DWG

STATE OF HAWAII
DEPARTMENT OF TRANSPORTATION
AIRPORTS

PROPOSAL

PROPOSAL TO THE STATE OF HAWAII
DEPARTMENT OF TRANSPORTATION
AIRPORTS

PROJECT: INSPECTION AND MAINTENANCE OF AIRPORT FIRE PROTECTION EQUIPMENT
DANIEL K. INOUE INTERNATIONAL AIRPORT,
DILLINGHAM AIRFIELD, AND KALAELOA AIRPORT
HONOLULU, OAHU, HAWAII

PROJECT NUMBERS: BO1542-43, BO2540-43, BO4540-43

TERM OF CONTRACT: Contract is for a term of one (1) year commencing from the date indicated in the Notice to Proceed from the State.

OPTION TO EXTEND: See Section 10.16

LIQUIDATED DAMAGES: For failure to provide satisfactory and timely maintenance services in accordance with the specifications as determined by the Director, liquidated damages shall be assessed the Contractor for each and every calendar day at the rate of five percent (5%) of the bid price of the maintenance service items.

The rate indicated above is applicable for each and every calendar day beyond the periods specified in Subsection 10.5 of the specifications on the frequency of services required.

TROUBLE CALLS: Five percent (5%) of the bid price maintenance service items' most current billing may be deducted from the State's payment to the Contractor for each and every time it does not respond within two (2) hours after receipt of a trouble call request for remedial maintenance for which it is contractually obligated under this contract. For purposes of this paragraph, definition of the term "respond" means to have the maintenance personnel on the job working on the equipment, which is the subject of the request.

ELECTRONIC SUBMITTAL: **Bidders shall submit and upload the complete proposal to HiePRO prior to the bid opening date and time. Any additional support documents explicitly designated as confidential and/or proprietary shall be uploaded as a separate file to HiePRO. See**

**SPECIAL PROVISIONS 2.4 DELIVERY OF
PROPOSALS TO HIePRO for complete details.
FAILURE TO UPLOAD THE COMPLETE PROPOSAL TO
HIePRO SHALL BE GROUNDS FOR REJECTION OF
THE BID.**

NOTE: BID, PERFORMANCE AND PAYMENT BONDS ARE NOT
REQUIRED FOR THIS PROJECT.

Director of Transportation
Aliiainmoku Hale
869 Punchbowl Street
Honolulu, Hawaii 96813

Dear Sir:

The undersigned bidder declares the following:

1. It has not, either directly or indirectly, entered into any agreement, participated in any collusion, or otherwise taken any action in restraint of free competitive bidding in connection with this proposal.
2. It has not been assisted or represented on this matter by any individual who has, in a State capacity, been involved in the subject matter of this contract within the past two years.
3. It has not and will not, either directly or indirectly offered or given a gratuity (i.e. an entertainment or gift) to any State or County employee to obtain a contract or favorable treatment under a contract.

The undersigned bidder further agrees to the following:

1. If this proposal is accepted, it shall execute a contract with the Department to provide all necessary labor, machinery, tools, equipment, apparatus and any other means of construction, to do all the work and to furnish all the materials specified in the contract in the manner and within the time therein prescribed in the contract, and that it shall accept in full payment therefore the sum of the unit and/or lump sum prices as set forth in the attached proposal schedule for the actual quantities of work performed and materials furnished and furnish satisfactory security in accordance with Section 103D-324, Hawaii Revised Statutes, within 10 days after the award of the contract or within such time as the Director of Transportation may allow after the undersigned has received the contract documents for execution, and is fully aware that non-compliance with the aforementioned terms will result in the forfeiture of the full amount of the bid guarantee required under Section 103D-323, Hawaii Revised Statutes.

2. That the quantities given in the attached proposal schedule are approximate only and are intended principally to serve as a guide in determining and comparing the bids.
3. That the Department does not either expressly or by implication, agree that the actual amount of work will correspond therewith, but reserves the right to increase or decrease the amount of any class or portion of the work, or to omit portions of the work, as may be deemed necessary or advisable by the Director of Transportation, and that all increased or decreased quantities of work shall be performed at the unit prices set forth in the attached proposal schedule except as provided for in the specifications.
4. In case of a discrepancy between unit prices and the totals in said Proposal Schedule, the unit prices shall prevail.
5. Agrees to begin work within 10 working days after the date of notification to commence with the work, which date is in the notice to proceed, and shall finish the entire project within the time prescribed.
6. The Director of Transportation reserves the right to reject any or all bids and to waive any defects when in the Director's opinion such rejections or waiver will be for the best interest of the public.

Receipt is hereby acknowledged and complete examination is hereby expressly guaranteed of the following listed items: the specifications, the notice to bidders, the special provisions, if any, the proposal, the plans, if any, and the contract form.

The undersigned acknowledges receipt of any addendum, issued by recording in the space below the date of receipt.

Addendum No. 1 _____ Addendum No. 3 _____

Addendum No. 2 _____ Addendum No. 4 _____

The undersigned hereby certifies that the bid prices contained in the attached proposal schedule have been carefully checked and are submitted as correct, final and are net prices.

Bidder (Company Name)

By _____
Authorized Signature

Print Name and Title

Business Address

Business Telephone Email

Date

Contact Person (If different from above)

Phone: _____ Email: _____

NOTE:

If bidder is a CORPORATION, the legal name of the corporation shall be set forth above, the corporate seal affixed, together with the signature(s) of the officer(s) authorized to sign contracts on behalf of the corporation. Please attach to this page current (not more than six months old) evidence of the authority of the officer(s) to sign on behalf of the corporation.

If bidder is a PARTNERSHIP, the true name of the partnership shall be set forth above with the signature(s) of the general partner(s) authorized to sign contracts on behalf of the partnership. Please attach to this page current (not more than six months old) evidence of the authority of the partner(s) to sign on behalf of the partnership.

If bidder is an INDIVIDUAL, the bidder's signature shall be placed in the space provided therefore on page PF-4.

If signature is by an agent, other than an officer of a corporation or a partner of a partnership, a POWER OF ATTORNEY must be on file with the Department prior to the opening of bids or submitted with the bid; otherwise, the bid may be rejected as irregular and unauthorized.

PROPOSAL SCHEDULE A
INSPECTION AND MAINTENANCE OF
AIRPORT FIRE PROTECTION EQUIPMENT
DANIEL K. INOUE INTERNATIONAL AIRPORT
ISLAND OF OAHU
PROJECT NO. BO1542-43

Item (A)	Description (B)	Quantity (C)	Unit	Unit Price (D)	Total (C X D)
A1	Monthly inspection and report of all portable and wheeled fire extinguishers, including ramp positions and jetways	13,321	Units	\$	\$
A2	Quarterly test of all fire sprinkler alarm devices at HNL	441	Units	\$	\$
A3	Semi-Annual inspection and report of Halon 1301 fire extinguishing system	16	Units	\$	\$
A4	Semi-Annual inspection and report of Clean Agent fire extinguishing systems	20	Units	\$	\$
A5	Annual maintenance inspection and report of all portable fire extinguishers at HNL, including ramp positions and jetways	1211	Units	\$	\$
A6	Annual maintenance inspection and report of all wheeled fire extinguishers at HNL, including ramp positions	107	Units	\$	\$
A7	Annual maintenance inspection and report of all fire hose units at HNL, including ramp positions	478	Units	\$	\$
A8	Annual test, inspection, certification and report of automatic fire sprinkler systems at HNL	107	Units	\$	\$
A9	Annual test, inspection of automatic fire sprinkler systems isolation valves at HNL	302	Units	\$	\$
A10	Annual test, inspection and verification on the operability of the Deluge Automatic Fire Sprinkler Systems at HNL	30	Units	\$	\$
A11	Annual test, inspection, certification and report of dry standpipe system at HNL	15	Units	\$	\$
A12	Annual test, inspection, certification and report of fire pump system at HNL (Terminal 1 and Terminal 2)	4	Units	\$	\$
A13	Regular working hours trouble Hours calls repair work	350	HRS	\$ _____/hr	\$
SUBTOTAL - A \$					_____

PROPOSAL SCHEDULE B
INSPECTION AND MAINTENANCE OF
AIRPORT FIRE PROTECTION EQUIPMENT
DANIEL K. INOUYE INTERNATIONAL AIRPORT
ISLAND OF OAHU
PROJECT NO. BO1542-43

Item (A)	Description (B)	Quantity (C)	Unit	Unit Price (D)	Total (C X D)
B1	100% Synthetic, Lined Fire Hose (see specs)	40	Units	\$	\$
B2	Plastic Hose Nozzle (see specs)	25	Units	\$	\$
B3	Adapter for Plastic Hose Nozzle	10	Units	\$	\$
B4	Hose Cabinets (see specs)	15	Units	\$	\$
B5	Hose Cabinet Locks (see specs)	25	Units	\$	\$
B6	Hose Cabinet Glass 6" x 6" or 8-1/2" x 6"	20	Units	\$	\$
B7	Hose Cabinet Glass 18" x 10"	2	Units	\$	\$
B8	Hose Cabinet Glass 27" x 9" or 27" x 10"	5	Units	\$	\$
B9	Hose Cabinet Door 27-3/4" x 27-3/4"	15	Units	\$	\$
B10	Fire Hose Rack Clip	5	Units	\$	\$
B11	Fire Hose Rack Extension Nipple	5	Units	\$	\$
B12	N2 Gauge for 150# Wheeled Fire Extinguisher	5	Units	\$	\$
B13	Nameplate for Wheeled Fire Extinguisher	5	Units	\$	\$
B14	N2 Hose for 150# Wheeled Fire Extinguisher	10	Units	\$	\$
B15	Discharge Nose for Wheeled Fire Extinguisher	10	Units	\$	\$
B16	Rubber Boot for Wheeled Fire Extinguisher	5	Units	\$	\$
B17	Automatic Fire Sprinkler Head	50	Units	\$	\$
B18	Allowance for Parts	Allowance	Allow.	Allowance	\$ 25,000.00
B19	5 lbs. Dry Chemical ABC	10	Units	\$	\$
B20	10 lbs. Dry Chemical ABC	60	Units	\$	\$
B21	20 lbs. Dry Chemical ABC	10	Units	\$	\$
B22	5 lbs. CO2	2	Units	\$	\$
B23	10 lbs. CO2	2	Units	\$	\$
B24	15 lbs. CO2	2	Units	\$	\$
B25	2-3/4 lbs. FE-36	1	Units	\$	\$
B26	9 lbs. FE-36	1	Units	\$	\$
B27	17 lbs. FE-36	1	Units	\$	\$

PROPOSAL SCHEDULE B
INSPECTION AND MAINTENANCE OF
AIRPORT FIRE PROTECTION EQUIPMENT
DANIEL K. INOUYE INTERNATIONAL AIRPORT
ISLAND OF OAHU
PROJECT NO. BO1542-43

Item (A)	Description (B)	Quantity (C)	Unit	Unit Price (D)	Total (C X D)
B28	150 lbs. Purple K (rubber wheels, fill fap indicator, quick opening valve, long-range nozzle, corrosion protection)	2	Units	\$	\$
B29	Reconditioning of 150# wheeled fire extinguisher (see specs)	12	Units	\$	\$
B30	Repairing and installation for flat tire on wheeled fire extinguisher (see specs)	5	Units	\$	\$
B31	Recharge Dry Chemical 2-3/4#	1	Units	\$	\$
B32	Recharge Dry Chemical 5#	30	Units	\$	\$
B33	Recharge Dry Chemical 6#	5	Units	\$	\$
B34	Recharge Dry Chemical 10#	62	Units	\$	\$
B35	Recharge Dry Chemical 20#	14	Units	\$	\$
B36	Recharge Dry Chemical 30#	1	Units	\$	\$
B37	Recharge Purple K 150#	5	Units	\$	\$
B38	Recharge CO2 15#	5	Units	\$	\$
B39	6-Year Blowdown and Re-Pressurize Dry Chemical 2-3/4#	1	Units	\$	\$
B40	6-Year Blowdown and Re-Pressurize Dry Chemical 5#	35	Units	\$	\$
B41	6-Year Blowdown and Re-Pressurize Dry Chemical 10#	10	Units	\$	\$
B42	6-Year Blowdown and Re-Pressurize Dry Chemical 20#	8	Units	\$	\$
B43	6-Year Blowdown and Re-Pressurize Dry Chemical 30#	3	Units	\$	\$
B44	6-Year Blowdown and Re-Pressurize Dry Chemical 200#	1	Units	\$	\$
B45	6-Year Blowdown and Re-Pressurize Purple K, 150#, Wheeled Fire Extinguisher	23	Units	\$	\$
B46	Hydro-Test up to 30# Fire Extinguisher	35	Units	\$	\$
B47	Hydro-Test 150# Wheeled Fire Extinguisher	21	Units	\$	\$
B48	Hydro-Test 200# Wheeled Fire Extinguisher	1	Units	\$	\$

PROPOSAL SCHEDULE B
 INSPECTION AND MAINTENANCE OF
 AIRPORT FIRE PROTECTION EQUIPMENT
 DANIEL K. INOUYE INTERNATIONAL AIRPORT
 ISLAND OF OAHU
 PROJECT NO. BO1542-43

Item (A)	Description (B)	Quantity (C)	Unit	Unit Price (D)	Total (C X D)
B49	Nitrogen Cylinder Hydro-Test 110#	20	Units	\$	\$
B50	Nitrogen Cylinder Recharge 110#	20	Units	\$	\$
B51	Recharge 2-1/2 Gallon Pressure Water Fire Extinguisher	13	Units	\$	\$
B52	Hydro-Test 2-1/2 Gallon Pressure Water Fire Extinguisher	13	Units	\$	\$
B53	Recoupling (see specs)	2	Units	\$	\$
SUBTOTAL - B					\$ _____

PROPOSAL SCHEDULE C
 INSPECTION AND MAINTENANCE OF
 AIRPORT FIRE PROTECTION EQUIPMENT
 DILLINGHAM AIRFIELD
 ISLAND OF OAHU
 PROJECT NO. BO2540-43

Item (A)	Description (B)	Quantity (C)	Unit	Unit Price (D)	Total (C X D)
C1	Monthly inspection and report of all portable and wheeled fire extinguishers at HDH	363	Units	\$	\$
C2	Annual maintenance inspection and report of all fire extinguishers at HDH	32	Units	\$	\$
C3	Annual maintenance inspection and report of all wheeled fire extinguishers at HDH	1	Units	\$	\$
C4	Regular working hours trouble Hours calls repair work	25	HRS	\$ _____/hr	\$
SUBTOTAL - C \$ _____					

PROPOSAL SCHEDULE D
INSPECTION AND MAINTENANCE OF
AIRPORT FIRE PROTECTION EQUIPMENT
DILLINGHAM AIRFIELD
ISLAND OF OAHU
PROJECT NO. BO2540-43

Item (A)	Description (B)	Quantity (C)	Unit	Unit Price (D)	Total (C X D)
D1	Allowance for Parts	Allowance	Allow.	Allowance	\$ 2,000.00
D2	5 lbs. Dry Chemical ABC	2	Units	\$	\$
D3	10 lbs. Dry Chemical ABC	4	Units	\$	\$
D4	20 lbs. Dry Chemical ABC	1	Units	\$	\$
D5	Recharge Dry Chemical 5#	3	Units	\$	\$
D6	Recharge Dry Chemical 10#	6	Units	\$	\$
D7	Recharge Dry Chemical 20#	1	Units	\$	\$
D8	6-Year Blowdown and Re-Pressurize Dry Chemical 5#	2	Units	\$	\$
D9	6-Year Blowdown and Re-Pressurize Dry Chemical 10#	4	Units	\$	\$
D10	6-Year Blowdown and Re-Pressurize Dry Chemical 20#	1	Units	\$	\$
D11	Hydro-Test up to 30# Fire Extinguisher	3	Units	\$	\$
D12	10 lbs. Fire Extinguisher Cabinet	5	Units	\$	\$
				SUBTOTAL - D \$	_____

PROPOSAL SCHEDULE E
INSPECTION AND MAINTENANCE OF
AIRPORT FIRE PROTECTION EQUIPMENT
KALAELOA AIRPORT
ISLAND OF OAHU
PROJECT NO. BO4540-43

Item (A)	Description (B)	Quantity (C)	Unit	Unit Price (D)	Total (C X D)
E1	Monthly inspection and report of all portable and wheeled fire extinguishers at JRF	451	Units	\$	\$
E2	Annual maintenance inspection and report of all portable fire extinguishers at JRF	106	Units	\$	\$
E3	Annual test, inspection and certification of fire sprinkler system at JRF, inclusive of valve exercising	3	Units	\$	\$
E4	Annual maintenance inspection and report of all wheeled fire extinguishers at JRF	2	Units	\$	\$
E5	Semi-Annual test, inspection and certification of fire range hood fire suppression system at JRF	2	Units	\$	\$
E6	Regular working hours trouble Hours calls repair work	25	HRS	\$ _____/hr	\$
SUBTOTAL - E					\$ _____

PROPOSAL SCHEDULE F
INSPECTION AND MAINTENANCE OF
AIRPORT FIRE PROTECTION EQUIPMENT
KALAELOA AIRPORT
ISLAND OF OAHU
PROJECT NO. BO4540-43

Item (A)	Description (B)	Quantity (C)	Unit	Unit Price (D)	Total (C X D)
F1	Allowance for Parts	Allowance	Allow.	Allowance	\$ 2,000.00
F2	5 lbs. Dry Chemical ABC	2	Units	\$	\$
F3	10 lbs. Dry Chemical ABC	4	Units	\$	\$
F4	Recharge Dry Chemical 5#	3	Units	\$	\$
F5	Recharge Dry Chemical 10#	6	Units	\$	\$
F6	6-Year Blowdown and Re-Pressurize Dry Chemical 5#	2	Units	\$	\$
F7	6-Year Blowdown and Re-Pressurize Dry Chemical 10#	4	Units	\$	\$
F8	Hydro-Test up to 30# Fire Extinguisher	3	Units	\$	\$
F9	10 lbs. Fire Extinguisher Cabinet	3	Units	\$	\$
SUBTOTAL - F \$					_____

PROPOSAL SCHEDULE
INSPECTION AND MAINTENANCE
OF AIRPORT FIRE PROTECTION EQUIPMENT

DANIEL K. INOUE INTERNATIONAL AIRPORT, PROJECT NO. BO1542-43
DILLINGHAM AIRFIELD, PROJECT NO. BO2540-43
KALAELOA AIRPORT, PROJECT NO. BO4540-43
ISLAND OF OAHU

PROPOSAL SCHEDULE SUMMARY

SUBTOTAL - A	\$ _____
SUBTOTAL - B	\$ _____
SUBTOTAL - C	\$ _____
SUBTOTAL - D	\$ _____
SUBTOTAL - E	\$ _____
SUBTOTAL - F	\$ _____
TOTAL AMOUNT FOR COMPARISON OF BIDS	\$ _____

NOTES:

1. Bids shall include all Federal, State, County and other applicable taxes and fees.
2. The TOTAL AMOUNT FOR COMPARISON OF BIDS shall be used to determine the lowest responsible bidder.
3. Bidders shall complete all unit prices and amounts. Failure to do so shall be grounds for rejection of bid.
4. In case of a discrepancy between unit price and the total in said bid, the unit price shall prevail.
5. The equipment listed in these specifications shall not be construed as being complete and accurate.
6. Payment(s) to the Contractor shall be made on the basis of actual number of service(s) performed or material supplied, and the unit bid prices.
7. Refer to Section 10 for requirements for servicing the equipment.

8. **Bidders shall submit and upload the complete proposal to HlePRO prior to the bid opening date and time. Proposals received after said due date and time shall not be considered. Any additional documents explicitly designated as confidential and/or proprietary shall be uploaded as a separate file to HlePRO. Do not include confidential and/or proprietary documents with the proposal. The record of each bidder and respective bid shall be open to public inspection. Original (wet ink, hard copy) proposal documents are not required to be submitted. Contract award shall be based on evaluation of proposal submitted and uploaded to HlePRO.**

FAILURE TO UPLOAD THE COMPLETE PROPOSAL TO HlePRO SHALL BE GROUNDS FOR REJECTION OF THE BID.

If there is a conflict between the specification document and the HlePRO solicitation, the specifications shall govern and control unless otherwise specified.

STATE OF HAWAII
DEPARTMENT OF TRANSPORTATION
AIRPORTS

FORMS

Contents:

Contract

Certificate for Performance of Services

CONTRACT

THIS AGREEMENT, made this day _____, by and between the STATE OF HAWAII, by its Director of Transportation, hereinafter referred to as "STATE", and «CONTRACTOR», «STATE_OF_INCORPORATON» whose business/post office address is «ADDRESS», hereinafter referred to as "CONTRACTOR";

WITNESSETH: That for and in consideration of the payments hereinafter mentioned, the CONTRACTOR hereby covenants and agrees with the STATE to furnish, perform and/or deliver and pay for all labor, supplies, materials, equipment and services called for in «PROJECT_NAME_AND_NO», or such a part thereof as shall be required by the STATE, the total amount of which labor, supplies, materials, equipment and services shall be computed at the unit and/or lump sum prices set forth in the attached proposal schedule and shall be the sum of «BASIC»-----DOLLARS (\$«BASIC_NUMERIC») as follows:

Total Amount for Comparison of Bids.....\$«BASIC_NUMERIC»

which sum shall be provided from State funds, all in accordance with the specifications, the special provisions, if any, the notice to bidders, the instructions to bidders, the proposal and plans, if any, for «PROJECT_NO_ONLY», on file in the office of the Director of Transportation. These documents, together with all alterations, amendments, and additions thereto and deductions therefrom, are attached hereto or incorporated herein by reference and made a part of this contract.

The CONTRACTOR hereby covenants and agrees to furnish, perform and/or deliver all labor, supplies, materials, equipment and services as provided herein «WORKING_DAYS» from the date indicated in the Notice to Proceed from the State, with an option to extend for TWO (2) additional TWELVE (12) MONTH periods subject to the terms specified in Section «SECTION_REFERENCING_OPTION_YEAR» of the Specifications. The total term of this contract shall not exceed THIRTY SIX (36) MONTHS.

For and in consideration of the covenants, undertakings and agreements of the CONTRACTOR herein set forth and upon the full and faithful performance thereof by the CONTRACTOR, the STATE hereby agrees to pay the CONTRACTOR the sum of «BASIC»-----DOLLARS (\$«BASIC_NUMERIC») in lawful money, such payment to be made, subject to such additions hereto or deductions therefrom heretofore or hereafter made, in the manner and at the time prescribed in the specifications and this contract.

An additional sum of «EXTRAS»-----DOLLARS (\$«EXTRA_NUMERIC») is hereby provided for extra work and shall be provided from State funds.

All words used herein in the singular shall extend to and include the plural. All words used in the plural shall extend to and include the singular. The use of any gender shall extend to and include all genders.

IN WITNESS WHEREOF, the parties hereto have caused this instrument to be duly executed the day and year first above written.

STATE OF HAWAII

Director of Transportation

«CONTRACTOR»

Signature

Print name

Print Title

Date

SAMPLE

CERTIFICATE FOR PERFORMANCE OF SERVICES

The undersigned bidder does hereby certify that in performing the services required for INSPECTION AND MAINTENANCE OF AIRPORT FIRE PROTECTION EQUIPMENT, DANIEL K. INOUE INTERNATIONAL AIRPORT, PROJECT NO. BO1542-43, DILLINGHAM AIRFIELD, PROJECT NO. BO2540-43, KALAELOA AIRPORT, PROJECT NO. BO4540-43, it will fulfill the following conditions:

1. All applicable laws of the Federal and State governments relating to workers' compensation, unemployment compensation, payment of wages, and safety will be fully complied with; and
2. The services to be rendered shall be performed by employees paid at wages or salaries not less than the wages paid to public officers and employees for similar work, with the exception of professional, managerial, supervisory, and clerical personnel who are not covered by Section 103-55, HRS.

I understand that failure to comply with the above conditions during the period of the contract shall result in cancellation of the contract, unless such noncompliance is corrected within a reasonable period as determined by the Director of Transportation. Payment in the final settlement of the contract or the release of bonds, if applicable, or both shall not be made unless the Director of Transportation has determined that the noncompliance has been corrected; and

I further understand that all payments required by Federal and State laws to be made by employers for the benefit of their employees are to be paid in addition to the base wage required by Section 103-55, HRS.

DATED at Honolulu, Hawaii, this ____ day of _____, 20__.

Name of Corporation, Partnership, or Individual

Signature and Title of Signer

NOTARY ACKNOWLEDGEMENT

Subscribed and sworn before me this
____ day of _____

Notary signature
Notary public, State of _____
My Commission Expires: _____

Doc. Date: _____ #Pages: ____
Notary Name: _____ Circuit
Doc. Description: _____

Notary signature
Date _____

NOTARY CERTIFICATION